

# 3722

## Dual 1×48, High Density, Multiplexer Card 96 differential channels, 300 Volts/1 Amp

- 96 two-pole or 48 four-pole channels for general purpose measurements
- Analog backplane connection relays provide easy bank and card interconnections
- 300V, 1A switched or 2A carry signal capacity; 60W, 125VA
- 1μV and 100pA offsets
- 25MHz bandwidth
- Relay closures stored in onboard memory
- Latching electromechanical relays
- Scan and measure over 110 channels/second

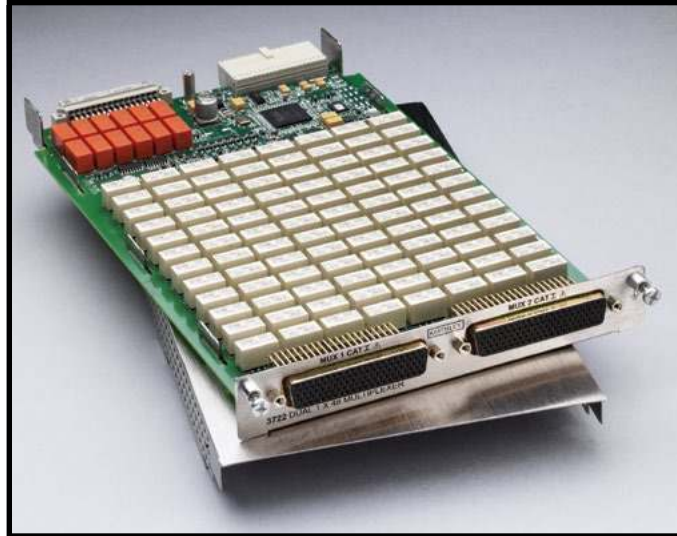

The Model 3722 offers two independent banks of 1×48 two-pole multiplexers, which is ideal for applications that require a high channel count. The two banks can automatically be connected to the Series 3700A mainframe backplane and optional DMM through the analog backplane connection relays. This connection allows the mainframe to reconfigure the card as a single 1×96 two-pole multiplexer or to enable card-to-card expansion for even larger configurations. Another feature of this card is the latching electromechanical relays. They can accommodate 300V, 1A switched signal levels.

The Model 3722 uses two 104-pin D-sub connectors for signal connections. A solder style connector kit (Model 3792-KIT104-R) and pre-assembled cables (Model 3722-MTC-1.5 and 3722-MTC-3) are available for card connections.

### Ordering Information

**3722**      **Dual 1×48, High Density, Multiplexer Card**

### ACCESSORIES AVAILABLE

3722-MTC-1.5	104-pin D-sub Male to Female Cable, 1.5m (5 ft.)
3722-MTC-1.5/MM	104-pin D-sub Male to Male Cable, 1.5m (5 ft.)
3722-MTC-3	104-pin D-sub Male to Female Cable, 3m (10 ft.)
3722-MTC-3/MM	104-pin D-sub Male to Male Cable, 3m (10 ft.)
3791-CIT	Contact Insertion and Extraction Tool
3792-KIT104-R	104-pin Male D-sub Connector kit (contains 2 male D-sub connectors with housings and 208 solder-cup contacts)
3792-KIT104-R/F	104-pin Female D-sub Connector kit (contains 2 female D-sub connectors with housings and 208 solder-cup contacts)

### SERVICES AVAILABLE

3722-3Y-EW-STD	1-year factory warranty extended to 3 years from date of shipment
3722-5Y-EW-STD	1-year factory warranty extended to 5 years from date of shipment
C/3722-3Y-STD	3 (Z540-1 compliant) calibrations within 3 years of purchase*

\*Not available in all countries

1.888.KEITHLEY (U.S. only)

[www.keithley.com](http://www.keithley.com)

# Dual 1×48, High Density, Multiplexer Card

96 differential channels, 300 Volts/1 Amp

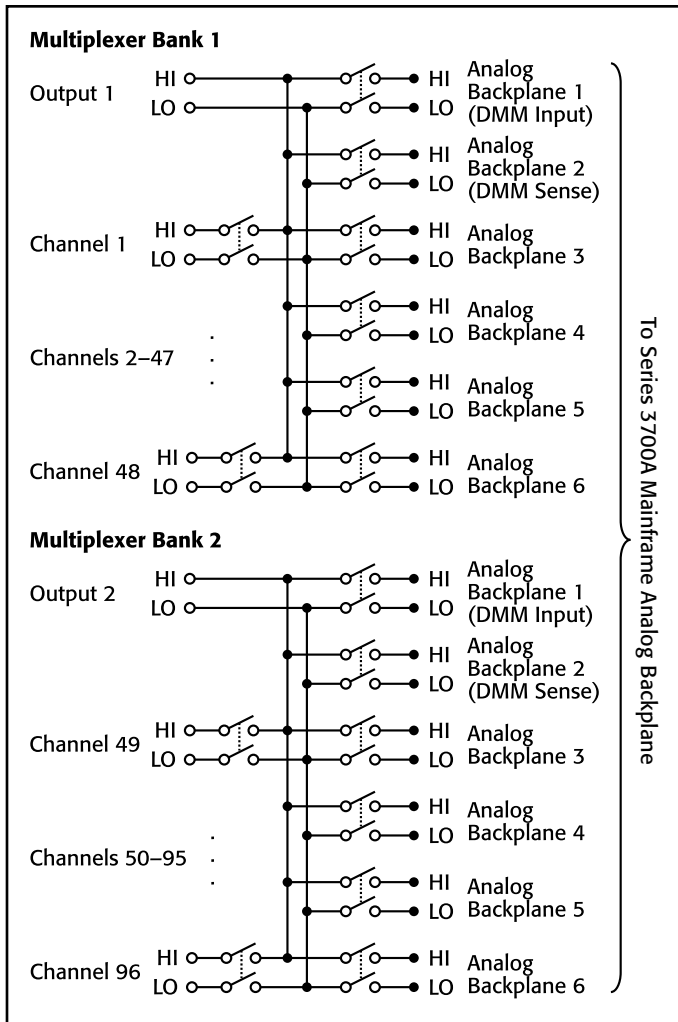

**MULTIPLEXER CONFIGURATION:** Two independent 1×48 2-pole multiplexers. Banks can be connected together via relays creating a single 1×96 multiplexer. Banks can be isolated from the backplane by relays. Card can be configured for 2- and 4-wire mode.

**CONTACT CONFIGURATION:** 2 pole form A.

**CONNECTOR TYPE:** Two 104 pin female D-shells.

**MAXIMUM SIGNAL LEVEL:** 300V DC or RMS, 1A switched (2A carry), 60W, 125VA.

**COMMON MODE VOLTAGE:** 300V DC or RMS between any terminal and chassis.

**VOLT-HERTZ LIMIT:** 8×10<sup>7</sup>.

**CONTACT LIFE:** >10<sup>5</sup> operations at maximum signal level. >10<sup>8</sup> operations no load.<sup>1</sup>

	Dual 1×48 <sup>2</sup>	Single 1×96
Channel Resistance (end of contact life)	<1.5 Ω	<2.5 Ω
Contact Potential (differential)	<±1 μV	<±2 μV
Offset Current	<100 pA	<100 pA
<b>Isolation</b>		
Differential	5×10 <sup>9</sup> Ω, 200 pF	5×10 <sup>9</sup> Ω, 400 pF
Bank-Bank	10 <sup>9</sup> Ω, 50 pF	—
Channel-channel	10 <sup>9</sup> Ω, 50 pF	10 <sup>9</sup> Ω, 50 pF
Common Mode	10 <sup>10</sup> Ω, 200 pF	10 <sup>10</sup> Ω, 400 pF
<b>Crosstalk Channel-channel</b>		
300kHz	<-65 dB	<-65 dB
1MHz	<-55 dB	<-55 dB
20MHz	<-30 dB	<-30 dB
<b>Bandwidth</b>	25 MHz	15 MHz

**TYPICAL SCANNING SPEEDS:**

**Switch Only<sup>3</sup>:** Sequential scanning, single channel, immediate trigger advance: >120 ch/s.

**With Measurements Into Memory<sup>4</sup>:**

DCV (10V range) or 2W Ohms (1kΩ range): >110 ch/s.

3- or 4-Wire RTD: >100 ch/s.

4-Wire Ohms (1kΩ range): >100 ch/s.

ACV (10V, 400Hz range): >110 ch/s.

**GENERAL**

**ACTUATION TIME:** 4ms.

**RELAY TYPE:** Latching electromechanical.

**RELAY DRIVE SCHEME:** Matrix.

**OPERATING ENVIRONMENT:** Specified for 0° to 50°C. Specified to 70% R.H. at 35°C.

**STORAGE ENVIRONMENT:** -25° to 65°C.

**WEIGHT:** 2.5 lbs.

**SAFETY:** Conforms to European Union Directive 73/23/EEC, EN61010-1.

**EMC:** Conforms to European Union Directive 2004/108/EC, EN61326-1.

**NOTES**

- Minimum signal level 10mV, 10μA.
- 3706A mainframe with all DMM backplane relays disconnected. Maximum two card backplane relays closed.
- Scanning script local to 3706A mainframe, within same bank, and break before make switching.
- 3706A mainframe with autorange off, limits off, dmm.autozero=0, dmm.autodelay=0, 4½ digits (NPLC=.006), for ACV dmm.detectorbandwidth=300, for OHMS dmm.offsetcompensation=off. Scanning script local to mainframe, sequential scan within same bank (2 pole) or card (4 pole), and break before make switching.