

2657A

High Power System SourceMeter[®] SMU Instrument



High power SourceMeter SMU instrument

- Source or sink up to 180W of DC or pulsed power ($\pm 3000V @ 20mA$, $\pm 1500V @ 120mA$)
- 1fA low current resolution
- Dual 22-bit precision ADCs and dual 18-bit $1\mu s$ per point digitizers for high accuracy and high speed transient capture
- Fully TSP[®] compliant for easy system integration with Series 2600B System SourceMeter models
- Combines a precision power supply, current source, DMM, arbitrary waveform generator, V or I pulse generator, electronic 18-bit load, and trigger controller – all in one instrument
- Includes TSP[®] Express characterization software, LabVIEW[®] driver, and Keithley's Test Script Builder software development environment

TYPICAL APPLICATIONS

- Power semiconductor device characterization and testing
- Characterization of GaN, SiC, and other compound materials and devices
- Breakdown and leakage testing to 3kV
- Characterization of sub-millisecond transients

The Model 2657A is a high voltage, high power, low current source measure unit (SMU) instrument that delivers unprecedented power, precision, speed, flexibility, and ease of use to improve productivity in R&D, production test, and reliability environments. The Model 2657A is designed specifically for characterizing and testing high voltage electronics and power semiconductors, such as diodes, FETs, and IGBTs, as well as other components and materials in which high voltage, fast response, and precise measurements of voltage and current are required. The Model 2657A offers the highest power and best low current performance in the industry. It is supported by the industry's most powerful parametric characterization software platforms to grow with you as your applications evolve.

The Model 2657A offers highly flexible, four-quadrant voltage and current source/load coupled with precision voltage and current meters. It can be used as a:

- Semiconductor characterization instrument
- V or I waveform generator
- V or I pulse generator
- Precision power supply with V and I readback
- True current source
- Digital multimeter (DCV, DCI, ohms, and power with $6\frac{1}{2}$ -digit resolution)
- Precision electronic load

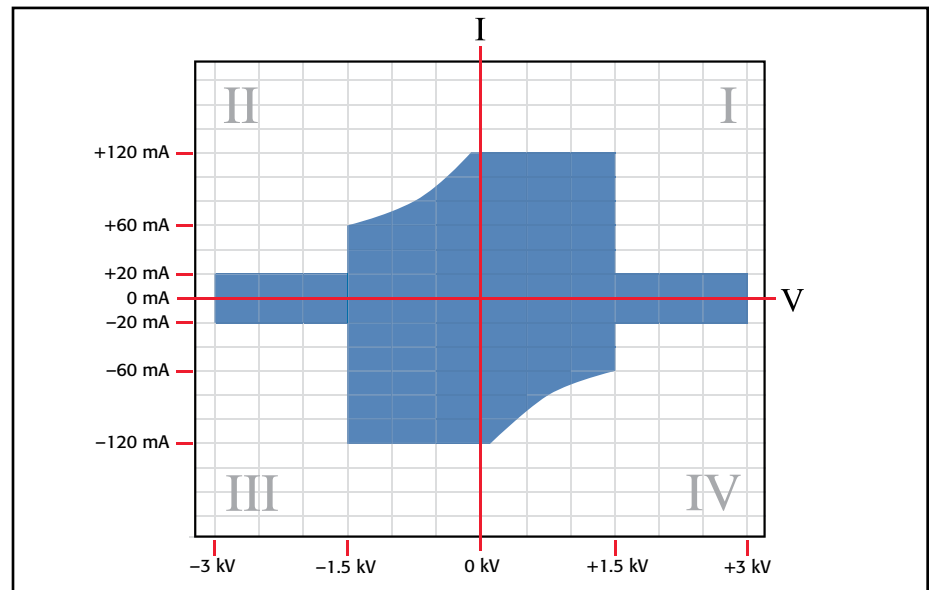

The Model 2657A can source or sink up to 3000V @ 20mA or 1500V @ 120mA.

SMU INSTRUMENTS

1.888.KEITHLEY (U.S. only)

www.keithley.com

A Greater Measure of Confidence

KEITHLEY
A Tektronix Company

2657A

Ordering Information

2657A High Power System SourceMeter SMU Instrument

Cables must be purchased separately. Please contact your local sales office for configuration assistance.

8010 High Power Device Test Fixture

Accessories Supplied

7709-308A Digital I/O and Interlock Connector

CA-180-3A TSP-Link/Ethernet Cable

Documentation CD

Software tools and drivers CD

ACCESSORIES AVAILABLE

2657A-LIM-3	Low Interconnect Module
2657A-PM-200	200V Protection Module
4299-6	Fixed Rack Mount Kit
SHV-CA-553-x*	High Voltage Triax to SHV Cable (1, 2, 3m)
HV-CA-554-x*	High Voltage Triax to Triax Cable (0.5, 1, 2, 3m)
HV-CA-571-3*	High Voltage Triax to Unterminated Cable
HV-CS-1613	High Voltage Triax Feedthrough Connector

* Cables must be purchased separately. Please contact your local sales office for configuration assistance.

ACCESSORIES SUPPLIED WITH THE 8010

CA-558-2	25-pin D-sub Interlock Cable for 26xxA
CA-560-x	4mm Black and Red Banana Cables, 8 in.
CA-562-x	6mm Black and Red Banana Cables, 10 in.
CA-563	BNC to Banana Cable, 9.5 in.
CA-568-120	Safety Earth Ground Cable
8010-DTB	Device Test Board with TO-247 Socket

ACCESSORIES AVAILABLE FOR THE 8010

8010-CTB	Customizable Test Board
8010-DTB-220	Device Test Board with TO-220 Socket (1.5kV)

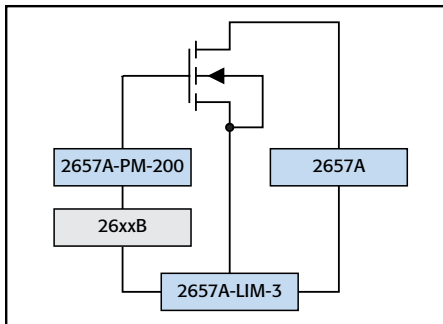

The Model 2657A can be combined with Series 2600B and Model 4200-SCS SMU instruments to support multi-terminal test capability. The Models 2657A-PM-200 Protection Module and 2657A-LIM-3 Low Interconnect Module make it easier to connect multiple instruments to a probe station safely (not required for connecting to the Model 8010 High Power Device Test Fixture).

High Power System SourceMeter SMU Instrument

Two Measurement Modes: Digitizing or Integrating

Precisely characterize transient and steady-state behavior, including rapidly changing thermal effects, with the two measurement modes in the Model 2657A. Each mode is defined by its independent analog-to-digital (A/D) converters.

The digitizing measurement mode provides speeds up to $1\mu\text{s}$ per sample. The dual 18-bit digitizers allow you to capture voltage and current transients simultaneously. In the integrating measurement mode, the dual 22-bit integrating analog to digital converters allow more precise measurement of voltage and current. Two A/D converters are used with each measurement mode, one for current and the other for voltage, that run simultaneously for accurate source readback that does not sacrifice test throughput.

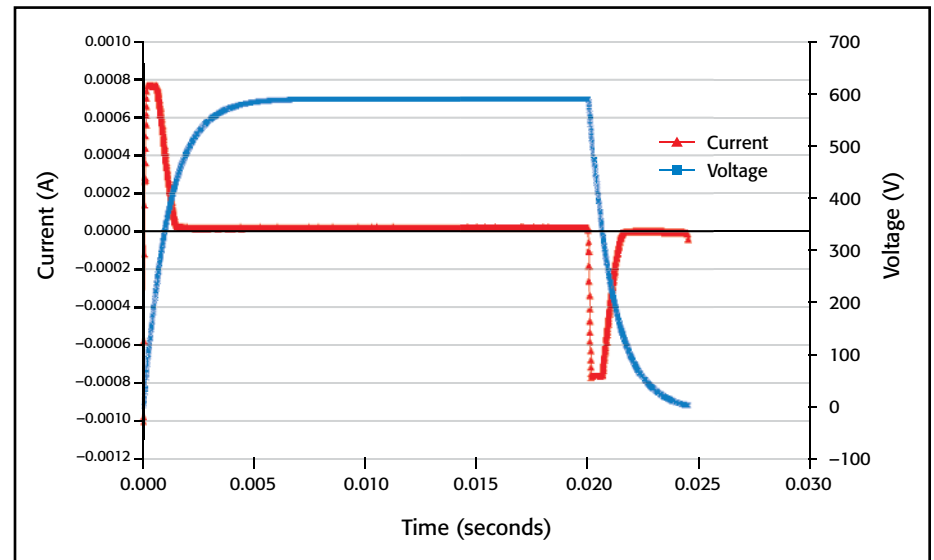

The dual high speed A/D converters sample as fast as $1\mu\text{s}$ per point, enabling full simultaneous characterization of both voltage and current.

Expansion Capabilities

Through TSP-Link Technology technology, the Model 2657A can be linked with Series 2600B SMU instruments to form a larger integrated system with up to 32 nodes. Precision timing and tight channel synchronization are guaranteed with built-in 500ns trigger controllers. The fully isolated, independent channels of the SourceMeter SMU instruments make true SMU-per-pin testing possible.

High Power Device Test Fixture

The Model 8010 High Power Device Test Fixture provides safe and easy connections for testing packaged high power devices at up to 3000V or 100A. The Model 8010 provides connections for a high voltage SourceMeter SMU instrument (Model 2657A), one or two high current SourceMeter SMU instruments (Model 2651A), and three low power SourceMeter SMU instruments (Series 2600B or Model 4200-SCS SMU instruments). This allows devices with two terminals (diodes) or three terminals (transistors) or even four or five terminals to be characterized safely and accurately. The Model 8010 has full interlock capability for up to six SourceMeter SMU instruments. The Model 8010 has integrated protection circuits that protect the low voltage SourceMeter SMU instruments from high voltages the Model 2657A can output should a device fault occur. The Model 8010 includes both a high current (100A) and a high voltage (3000V) test socket. Various replacement test socket modules are available, including TO-247, TO-220, axial lead, and a blank socket module that allows building a custom socket. In addition to standard banana jumpers, the Model 8010 has rear-panel scope and thermal probe ports to simplify system integration.

1.888.KEITHLEY (U.S. only)

www.keithley.com

A Greater Measure of Confidence

KEITHLEY

A Tektronix Company

2657A

High Power System SourceMeter SMU Instrument

Standard Capabilities of Series 2600B SMU Instruments

Each Model 2657A includes all the features and capabilities provided in Series 2600B SourceMeter SMU instruments:

- Flexibility for use as either a bench-top I-V characterization tool or as a building block component of multiple channel I-V test systems.
- TSP Express software to perform common I-V tests quickly and easily without programming or installing software.
- ACS Basic Edition software for semiconductor component characterization (optional). ACS Basic Edition now features a "Trace" mode for generating a suite of characteristic curves.
- Keithley's Test Script Processor (TSP) technology supports creating and running custom user test scripts for high speed test automation, as well as creating programming sequences that allow the instrument to operate asynchronously without direct PC control.
- Parallel test execution and precision timing when multiple Series 2600B SMU instruments are connected together in a system.
- LXI Class C compliance.
- 14 digital I/O lines for direct connection to a probe station, component handler, or other automation tools.
- USB port for extra data and test program storage via USB memory device.

Model 2657A Condensed Specifications

VOLTAGE ACCURACY SPECIFICATIONS ¹

Range	SOURCE		MEASURE		
	Programming Resolution	Accuracy \pm (% rdg + volts)	Display Resolution	Integrating ADC Accuracy ² \pm (% rdg + volts)	High Speed ADC Accuracy ³ \pm (% rdg + volts)
200 V	5 mV	0.03% + 50 mV	100 μ V	0.025% + 50 mV	0.05% + 100 mV
500 V	10 mV	0.03% + 125 mV	100 μ V	0.025% + 100 mV	0.05% + 200 mV
1500 V	40 mV	0.03% + 375 mV	1 mV	0.025% + 300 mV	0.05% + 600 mV
3000 V	80 mV	0.03% + 750 mV	1 mV	0.025% + 600 mV	0.05% + 1.2 V

CURRENT ACCURACY SPECIFICATIONS ⁴

Range	SOURCE		MEASURE		
	Programming Resolution	Accuracy \pm (% rdg + amps)	Display Resolution	Integrating ADC Accuracy ² \pm (% rdg + amps)	High Speed ADC Accuracy ³ \pm (% rdg + amps)
1 nA	30 fA	0.1% + 2E ⁻¹² + VoE ⁻¹⁵	1 fA	0.1% + 6E ⁻¹³ + VoE ⁻¹⁵	0.2% + 6E ⁻¹³ + VoE ⁻¹⁵
10 nA	300 fA	0.1% + 5E ⁻¹² + VoE ⁻¹⁵	10 fA	0.1% + 5E ⁻¹² + VoE ⁻¹⁵	0.2% + 5E ⁻¹² + VoE ⁻¹⁵
100 nA	3 pA	0.1% + 6E ⁻¹¹ + VoE ⁻¹³	100 fA	0.1% + 6E ⁻¹¹ + VoE ⁻¹³	0.2% + 6E ⁻¹¹ + VoE ⁻¹³
1 μ A	30 pA	0.03% + 700 pA	1 pA	0.025% + 400 pA	0.08% + 800 nA
10 μ A	300 pA	0.03% + 5 nA	10 pA	0.025% + 1.5 nA	0.08% + 3 nA
100 μ A	3 nA	0.03% + 60 nA	100 pA	0.02 % + 25 nA	0.05% + 50 nA
1 mA	30 nA	0.03% + 300 nA	1 nA	0.02 % + 200 nA	0.05% + 400 nA
2 mA	60 nA	0.03% + 1.2 μ A	1 nA	0.02 % + 500 nA	0.05% + 1 μ A
20 mA	600 nA	0.03% + 12 μ A	10 nA	0.02 % + 5 μ A	0.05% + 10 μ A
120 mA	3 μ A	0.03% + 36 μ A	100 nA	0.02 % + 24 μ A	0.05% + 50 μ A

1. For temperatures 0° to 18°C and 28° to 50°C, accuracy is degraded by $\pm(0.15 \times \text{accuracy specification})^{\circ}\text{C}$.

2. Derate accuracy specification for NPLC setting <1 by increasing error term. Add appropriate typical percent of range term for resistive loads using the table below.

NPLC Setting	200 V and 500 V Ranges	1500 V and 3000 V Ranges	100 nA Range	1 μ A to 120 mA Ranges
0.1	0.01%	0.01%	0.01%	0.01%
0.01	0.08%	0.07%	0.1 %	0.05%
0.001	0.8 %	0.6 %	1 %	0.5 %

3. 18-bit ADC. Average of 1000 samples taken at 1 μ s intervals.

4. For temperatures 0° to 18°C and 28° to 50°C, accuracy is degraded by $\pm(0.35 \times \text{accuracy specification})^{\circ}\text{C}$.

SUPPLEMENTAL CHARACTERISTICS

TYPICAL VOLTAGE SOURCE NOISE: 0.005% of range.

TYPICAL CURRENT SOURCE NOISE: 0.08% of range.

TYPICAL VOLTAGE SOURCE SETTling: <1ms to 200V, <7ms to 3000V.

TYPICAL CURRENT SOURCE SETTling: <5ms to 120mA, <200ms to 1 μ A.

Specifications are subject to change without notice.



Model 8010 High Power Device Test Fixture

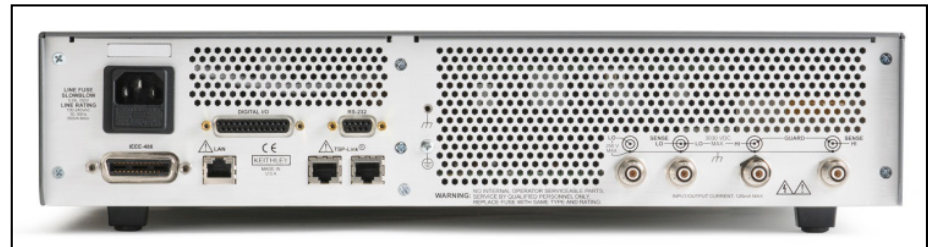

Model 2657A rear panel

1.888.KEITHLEY (U.S. only)

www.keithley.com

KEITHLEY

A Tektronix Company

A Greater Measure of Confidence

2657A

High Power System SourceMeter SMU Instrument

TRIGGERING AND SYNCHRONIZATION SPECIFICATIONS

TRIGGERING: Trigger In to Trigger Out: 0.5 μ s, typical.

SYNCHRONIZATION: Single- or multi-node synchronized source change: <0.5 μ s, typical.

PROGRAMMING

TEST SCRIPT BUILDER: Integrated development environment for building, running, and managing TSP scripts.

TSP EXPRESS (Embedded): Tool that allows users to perform common I-V tests quickly and easily without programming or installing software.

SOFTWARE INTERFACE: TSP Express (Embedded), Direct GPIB/VISA, Read/Write with VB, VC/C++, VC#, LabVIEW™, TestPoint™, LabWindows™/CVI, etc.

SYSTEM EXPANSION

The TSP-Link expansion interface allows TSP-enabled instruments to trigger and communicate with each other. See figure below:

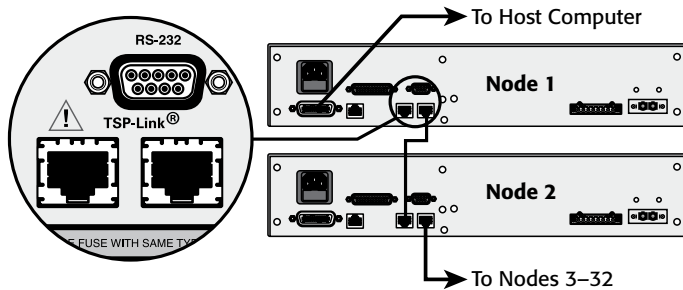

GENERAL

USB: USB 2.1 Host Controller, supports external data storage.

CONTACT CHECK: $\pm 50\Omega$.

PC INTERFACE: IEEE-488.1 and .2; LXI Ethernet; RS-232.

DIGITAL I/O INTERFACE: Input/Output Pins: 14 open drain I/O bits. 5.25V max.

POWER SUPPLY: 100V to 250VAC, 50Hz–60Hz (auto sensing), 550VA max.

COOLING: Forced air. Side and top intake and rear exhaust.

EMC: Conforms to European Union EMC Directive.

SAFETY: ETL listed (PENDING). Conforms to European Union Low Voltage Directive.

WARRANTY: 1 year.

DIMENSIONS: 89mm high \times 435mm wide \times 549mm deep (3.5 in \times 17.1 in \times 21.6 in). Bench Configuration (with handle and feet): 104mm high \times 483mm wide \times 620mm deep (4.1 in \times 19 in \times 24.4 in).

WEIGHT: 9.98kg (22 lbs).

ENVIRONMENT: For indoor use only.

CALIBRATION PERIOD: One year.

Specifications are subject to change without notice. All Keithley trademarks and trade names are the property of Keithley Instruments. All other trademarks and trade names are the property of their respective companies.



A Greater Measure of Confidence

KEITHLEY INSTRUMENTS ■ 28775 AURORA RD. ■ CLEVELAND, OH 44139-1891 ■ 440-248-0400 ■ Fax: 440-248-6168 ■ 1-888-KEITHLEY ■ www.keithley.com

BENELUX
+31-40-267-5506
www.keithley.nl

FRANCE
+33-01-69-86-83-60
www.keithley.fr

ITALY
+39-049-762-3950
www.keithley.it

MALAYSIA
60-4-643-9679
www.keithley.com

SINGAPORE
01-800-8255-2835
www.keithley.com.sg

BRAZIL
55-11-4058-0229
www.keithley.com

GERMANY
+49-89-84-93-07-40
www.keithley.de

JAPAN
81-120-441-046
www.keithley.jp

MEXICO
52-55-5424-7907
www.keithley.com

TAIWAN
886-3-572-9077
www.keithley.com.tw

CHINA
86-10-8447-5556
www.keithley.com.cn

INDIA
080-30792600
www.keithley.in

KOREA
82-2-6917-5000
www.keithley.co.kr

RUSSIA
+7-495-664-7564
www.keithley.ru

UNITED KINGDOM
+44-1344-39-2450
www.keithley.co.uk

For further information on how to purchase or to locate a sales partner please visit www.keithley.com/buy