

B1505A Power Device Analyzer/ Curve Tracer

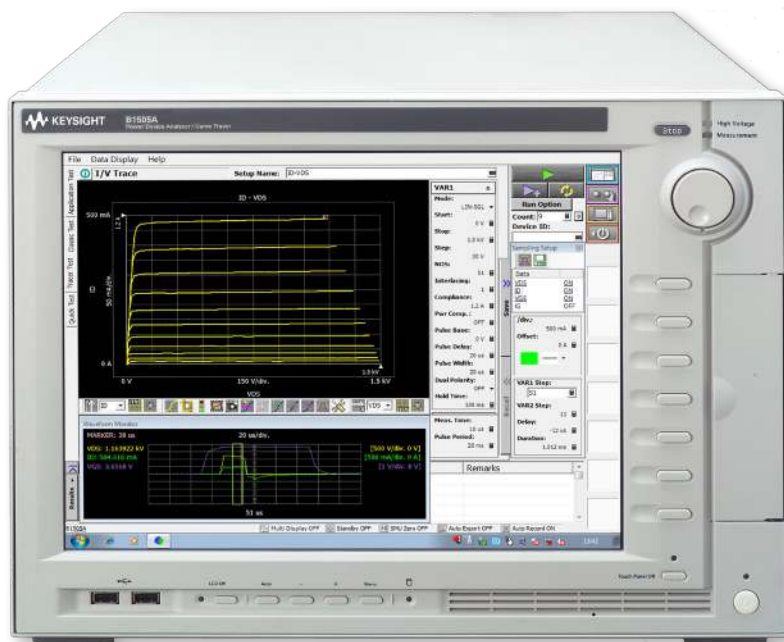

Introduction

The Keysight Technologies, Inc. B1505A Power Device Analyzer/Curve Tracer is a single-box solution with next-generation curve tracer functionality that can accurately evaluate and characterize power devices at up to 10 kV and 1500 A. The B1505A is capable of handling all types of power device evaluation, with features that include a wide voltage and current range, fast pulsing capability (10 μ s), $\mu\Omega$ level on-resistance measurement resolution and sub-pA level current measurement capability. In addition, an oscilloscope view permits visual verification of both current and voltage pulsed waveforms.

Two independent analog-to-digital (A/D) converters on each channel support a 2 μ s sampling rate for accurate monitoring of the critical timings that can affect device behavior.

It can also perform fully automated capacitance measurements (such as Ciss, Coss and Crss) at high voltage biases (up to 3 kV). Moreover, it can evaluate gate charge (which is an important parameter for high frequency switching converter efficiency) at up to 3 kV as well. The B1505A with EasyEXPERT group+ software includes a curve tracer mode that combines familiar curve tracer functionality with the convenience of a PC-based instrument; this makes it easy for traditional curve-tracer users to become productive quickly. Module selector, device capacitance selector and Quick Test feature enable fully automated measurement on multiple parameters without the need to recable. Keysight EasyEXPERT group+ GUI based characterization software is available either on the B1505A's embedded Windows 10 platform with 15-inch touch screen or on your PC to accelerate the characterization tasks. It supports efficient and repeatable device characterization in the entire characterization process from measurement setup and execution to analysis and data management either interactive manual operation or automation across a wafer in conjunction with a semiautomatic wafer prober. EasyEXPERT group+ makes it easy to perform complex device characterization immediately with hundreds of ready-to-use measurements (application tests) furnished, and allows you the option of storing test condition and measurement data automatically after each measurement in a unique built-in database (workspace), ensuring that valuable information is not lost and that measurements can be repeated at a later date. The net result is improved ease of use, better data analysis and simplified data management for the measurement of power devices and power circuitry.

Basic features

Precision measurement across a wide range of operating conditions

- All-in-one solution for power device characterization up to 1500 A/10 kV
- Medium current measurement with high voltage bias (e.g. 500 mA at 1200 V).
- $\mu\Omega$ resistance measurement capability
- Accurate sub-picoamp level current measurement at high voltage bias
- Fully automated thermal test from -50 to +250 °C

Extensive device evaluation capabilities

- Fully automated Capacitance (Ciss, Coss, Crss, etc.) measurement at up to 3000 V of DC bias
- High power pulsed measurements down to 10 μ s
- Gate charge measurement covering Nch MOSFETs and IGBTs both in package and on wafer
- High voltage/high current fast switch option to characterize GaN current collapse effect
- Up to 5 high voltage (3 kV) source/measure unit channels for reliability applications
- Perform both hot and cold temperature dependency testing in an interlock equipped test fixture

Improved measurement efficiency

- Switch between high-voltage and high-current measurements without the need to recable
- Automated reconfiguration of test circuitry for transistor capacitance measurement (Ciss, Coss, Crss, Cgs, Cgd, Cds, etc.) for both packaged and on-wafer devices
- Standard test fixtures with interlock for safe packaged power device testing
- Supported and secure on-wafer high-power testing over 200 A and up to 10 kV

- Oscilloscope view allows verification of applied voltage and current waveforms
- MS Windows-based EasyEXPERT group+ software facilitates data management and simplifies data analysis

Upgradable and scalable hardware architecture

- A wide selection of measurement modules
- Support for high power devices with up to 6 pins

GPIO, USB, LAN interfaces and VGA video output port

Self-test, self-calibration, diagnostics

Specification conditions

The measurement and output accuracy are specified under the conditions listed below. Note: The SMU measurement and output accuracies are specified at the SMU connector terminals, using the Zero Check terminal as a reference.

1. Temperature: 23 ± 5 °C
2. Humidity: 20 to 70%
3. Self-calibration after a 40 minute warm-up is required.
4. Ambient temperature change less than ± 1 °C after self-calibration execution. (Note: This does not apply to the MFCMU).
5. Measurement made within one hour after self-calibration execution. (Note: This does not apply to the MFCMU).
6. Calibration period: 1 year
7. SMU integration time setting:
1 PLC (1 nA to 1 A range, voltage range), 200 μ s (20 A range)
Averaging of high-speed ADC:
128 samples per 1 PLC

8. SMU filter: ON (for HPSMU and MPSMU)
9. SMU measurement terminal connection: Kelvin connection (for HPSMU, MPSMU, HCSMU and MCSMU), non-Kelvin (for HVSMU)

Note: This document lists specifications and supplemental characteristics for the B1505A and its associated modules. The specifications are the standards against which the B1505A and its associated modules are tested. When the B1505A or any of its associated modules are shipped from the factory, they meet the specifications. The “supplemental” characteristics described in the following specifications are not guaranteed, but provide useful information about the functions and performance of the instrument.

Note: Module upgrades to existing B1505A systems must be carried out at a Keysight Technologies, Inc. service centre. In order to ensure system specifications the new modules need to be installed and the complete unit calibrated. Contact your nearest Keysight Technologies office to arrange the installation and calibration of new B1505A modules.

B1505A Specifications

Supported plug-in modules

The B1505A supports ten slots for plug-in modules.

Part number	Description	Slots occupied	Range of operation	Measure resolution
B1510A	High Power Source Monitor Unit (HPSMU)	2	-200 V to 200 V, -1 A to 1 A	2 μ V, 10 fA
B1511B	Medium Power Source Monitor Unit (MPSMU)	1	-100 V to 100 V, -100 mA to 100 mA	0.5 μ V, 10 fA
B1512A	High Current Source Monitor Unit (HCSMU)	2	-40 V to 40 V, -1 A to 1 A -20 V to 20 V, -20 A to 20 A (Pulse only)	200 nV, 10 pA
B1513C	High Voltage Source Monitor Unit (HVSMU)	2	-3000 V to 3000 V, -4 mA to 4 mA -1500 V to 1500 V, -8 mA to 8 mA	200 μ V, 10 fA
B1514A	Medium Current Source Monitor Unit (MCSMU)	1	-30 V to 30 V, -100 mA to 100 mA -30 V to 30 V, -1 A to 1 A (Pulse only)	200 nV, 10 pA
B1520A ¹	Multi Frequency Capacitance Measurement Unit (MFCMU)	1	1 kHz to 5 MHz	

1. N1300A-100 SMU CMU Unify Unit (SCUU) is not supported for the B1505A.

Maximum module configuration

The total power consumption of all modules cannot exceed 84 W. Under this rule, the B1505A can contain any combination of the following SMUs:

- Up to 4 dual-slot HPSMUs¹
- Up to 10 single-slot MPSMUs
- Up to 2 dual-slot HCSMUs¹
- Up to 6 single-slot MCSMUs
- Up to 5 dual-slot HVSMU

In addition, up to 1 single-slot MFCMU can be installed per B1505A mainframe for any of the above listed SMU configurations.

The installation order of the modules is: HPSMU, MPSMU, MFCMU, MCSMU, HCSMU and HVSMU starting from the bottom of the B1505A mainframe.

Maximum voltage between Common and Ground

$\leq \pm 42$ V

Ground unit (GNDU) specifications

The GNDU is furnished with the B1505A mainframe.

Output voltage: 0 V \pm 100 μ V

1. The total number of installed HPSMU and HCSMU modules cannot exceed 4.

Maximum sink current: ± 4.2 A
Output terminal/connection:
Triaxial connector, Kelvin
(remote sensing)

GNDU supplemental characteristics

Load capacitance: 1 μ F

Cable resistance:

For $I_S \leq 1.6$ A: Force line R < 1 Ω

For 1.6 A < $I_S \leq 2.0$ A: Force line R < 0.7 Ω

For 2.0 A < $I_S \leq 4.2$ A: Force line R < 0.35 Ω

For all cases: Sense line R ≤ 10 Ω

Where I_S is the current being sunk by the GNDU.

Peripherals and interface

Data storage
SSD, DVD-R drive

Interfaces

GPIB, interlock, USB (USB 2.0, front 2, rear 2), LAN (1000BASE-T/100BASE-TX/10BASE-T), trigger in/out, digital I/O, VGA video output

Remote control capabilities

- FLEX commands (GPIB)
- EasyEXPERT group+ remote control function (LAN)

Trigger I/O

Only available using GPIB FLEX commands.

Trigger in/out synchronization pulses before and after setting and measuring DC voltage and current. Arbitrary trigger events can be masked or activated independently.

Furnished software

- EasyEXPERT group+
- MDM file converter

This tool can convert the EasyEXPERT group+ file (XTR/ZTR) to Keysight IC-CAP MDM file format.

The EasyEXPERT file of the following measurements performed in the classic mode is only supported:

- IV Sweep
- Multi channel IV Sweep
- CV Sweep

- 4155/56 setup file converter tool

This tool can convert 4155 and 4156 measurement setup files (file extensions MES or DAT) into equivalent EXPERT group+ classic test mode setup files

HPSMU Module Specifications

Voltage range, resolution, and accuracy (high resolution ADC)					
Voltage range	Force resolution	Measure resolution	Force accuracy ¹ ±(% + mV)	Measure accuracy ¹ ±(% + mV)	Maximum current
±2 V	100 µV	2 µV	±(0.018 + 0.4)	±(0.01 + 0.14)	1 A
±20 V	1 mV	20 µV	±(0.018 + 3)	±(0.009 + 0.9)	1 A
±40 V	2 mV	40 µV	±(0.018 + 6)	±(0.01 + 1)	500 mA
±100 V	5 mV	100 µV	±(0.018 + 15)	±(0.012 + 2.5)	125 mA
±200 V	10 mV	200 µV	±(0.018 + 30)	±(0.014 + 2.8)	50 mA

1. ± (% of reading value + offset value in mV)

Current range, resolution, and accuracy (high resolution ADC)					
Current range	Force resolution	Measure resolution	Force accuracy ¹ ±(% + A + A)	Measure accuracy ¹ ±(% + A + A)	Maximum voltage
±1 nA	50 fA	10 fA	±(0.1 + 3E-13 + Vo x 1E-15)	±(0.1 + 2E-13 + Vo x 1E-15)	200 V
±10 nA	500 fA	10 fA	±(0.1 + 3E-12 + Vo x 1E-14)	±(0.1 + 1E-12 + Vo x 1E-14)	200 V
±100 nA	5 pA	100 fA	±(0.05 + 3E-11 + Vo x 1E-13)	±(0.05 + 2E-11 + Vo x 1E-13)	200 V
±1 µA	50 pA	1 pA	±(0.05 + 3E-10 + Vo x 1E-12)	±(0.05 + 1E-10 + Vo x 1E-12)	200 V
±10 µA	500 pA	10 pA	±(0.05 + 3E-9 + Vo x 1E-11)	±(0.04 + 2E-9 + Vo x 1E-11)	200 V
±100 µA	5 nA	100 pA	±(0.035 + 15E-9 + Vo x 1E-10)	±(0.03 + 3E-9 + Vo x 1E-10)	200 V
±1 mA	50 nA	1 nA	±(0.04 + 15E-8 + Vo x 1E-9)	±(0.03 + 6E-8 + Vo x 1E-9)	200 V
±10 mA	500 nA	10 nA	±(0.04 + 15E-7 + Vo x 1E-8)	±(0.03 + 2E-7 + Vo x 1E-8)	200 V
±100 mA	5 µA	100 nA	±(0.045 + 15E-6 + Vo x 1E-7)	±(0.04 + 6E-6 + Vo x 1E-7)	200 V ²
±1 A	50 µA	1 µA	±(0.4 + 3E-4 + Vo x 1E-6)	±(0.4 + 15E-5 + Vo x 1E-6)	200 V ²

1. ± (% of reading value + fixed offset in A + proportional offset in A), Vo is the output voltage in V.

2. 200 V (Io ≤ 50 mA), 100 V (50 mA < Io ≤ 125 mA), 40 V (125 mA < Io ≤ 500 mA), 20 V (500 mA < Io ≤ 1 A), Io is the output current in A.

Voltage range, resolution, and accuracy (high speed ADC)					
Voltage range	Force resolution	Measure resolution	Force accuracy ¹ ±(% + mV)	Measure accuracy ¹ ±(% + mV)	Maximum current
±2 V	100 µV	100 µV	±(0.018 + 0.4)	±(0.01 + 0.7)	1 A
±20 V	1 mV	1 mV	±(0.018 + 3)	±(0.01 + 4)	1 A
±40 V	2 mV	2 mV	±(0.018 + 6)	±(0.015 + 8)	500 mA
±100 V	5 mV	5 mV	±(0.018 + 15)	±(0.02 + 20)	125 mA
±200 V	10 mV	10 mV	±(0.018 + 30)	±(0.035 + 40)	50 mA

1. ±(% of reading value + offset value in mV). Averaging is 128 samples in 1 PLC.

Current range, resolution, and accuracy (high speed ADC)					
Current range	Force resolution	Measure resolution	Force accuracy ¹ ±(% + A + A)	Measure accuracy ¹ ±(% + A + A)	Maximum voltage
±1 nA	50 fA	50 fA	±(0.1 + 3E-13 + Vo x 1E-15)	±(0.25 + 3E-13 + Vo x 1E-15)	200 V
±10 nA	500 fA	500 fA	±(0.1 + 3E-12 + Vo x 1E-14)	±(0.25 + 2E-12 + Vo x 1E-14)	200 V
±100 nA	5 pA	5 pA	±(0.05 + 3E-11 + Vo x 1E-13)	±(0.1 + 2E-11 + Vo x 1E-13)	200 V
±1 µA	50 pA	50 pA	±(0.05 + 3E-10 + Vo x 1E-12)	±(0.1 + 2E-10 + Vo x 1E-12)	200 V
±10 µA	500 pA	500 pA	±(0.05 + 3E-9 + Vo x 1E-11)	±(0.05 + 2E-9 + Vo x 1E-11)	200 V
±100 µA	5 nA	5 nA	±(0.035 + 15E-9 + Vo x 1E-10)	±(0.05 + 2E-8 + Vo x 1E-10)	200 V
±1 mA	50 nA	50 nA	±(0.04 + 15E-8 + Vo x 1E-9)	±(0.04 + 2E-7 + Vo x 1E-9)	200 V
±10 mA	500 nA	500 nA	±(0.04 + 15E-7 + Vo x 1E-8)	±(0.04 + 2E-6 + Vo x 1E-8)	200 V
±100 mA	5 µA	5 µA	±(0.045 + 15E-6 + Vo x 1E-7)	±(0.1 + 2E-5 + Vo x 1E-7)	200 V ²
±1 A	50 µA	50 µA	±(0.4 + 3E-4 + Vo x 1E-6)	±(0.5 + 3E-4 + Vo x 1E-6)	200 V ²

1. ±(% of reading value + fixed offset in A + proportional offset in A), Vo is the output voltage in V.

2. 200 V (Io ≤ 50 mA), 100 V (50 mA < Io ≤ 125 mA), 40 V (125 mA < Io ≤ 500 mA), 20 V (500 mA < Io ≤ 1 A), Io is the output current in A.

Power consumption

Voltage source mode:	
Voltage range	Power
2 V	$20 \times I_c$ (W)
20 V	$20 \times I_c$ (W)
40 V	$40 \times I_c$ (W)
100 V	$100 \times I_c$ (W)
200 V	$200 \times I_c$ (W)

Where I_c is the current compliance setting.

Current source mode:	
Voltage compliance	Power
$V_c \leq 20$	$20 \times I_o$ (W)
$20 < V_c \leq 40$	$40 \times I_o$ (W)
$40 < V_c \leq 100$	$100 \times I_o$ (W)
$100 < V_c \leq 200$	$200 \times I_o$ (W)

Where V_c is the voltage compliance setting and I_o is output current.

HPSMU measurement and output range

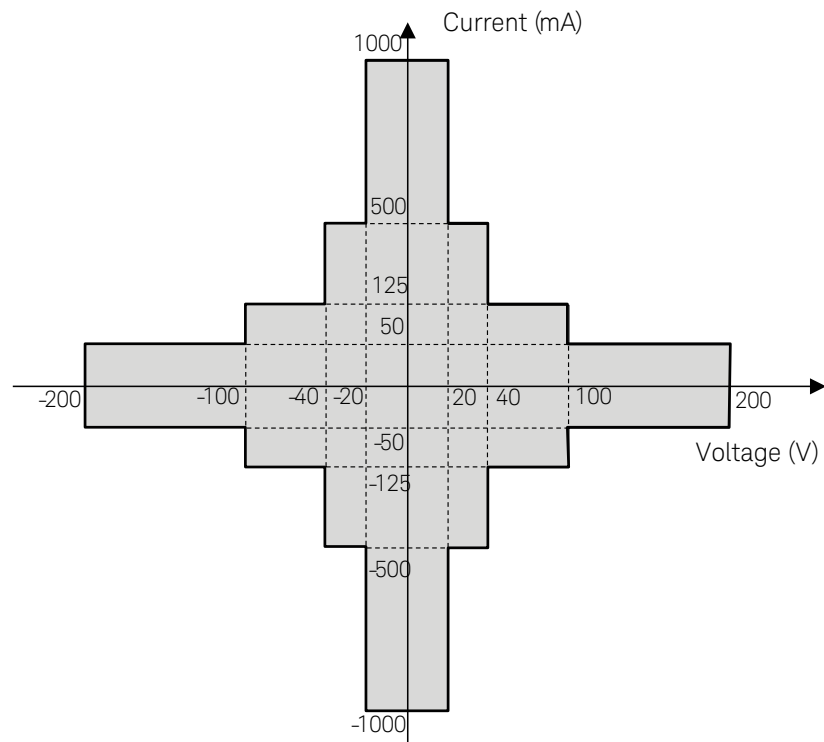

MPSMU Module Specifications

Voltage range, resolution, and accuracy (high resolution ADC)					
Voltage range	Force resolution	Measure resolution	Force accuracy ¹ ±(% + mV)	Measure accuracy ¹ ±(% + mV)	Maximum current
±0.5 V	25 µV	0.5 µV	±(0.018 + 0.15)	±(0.01 + 0.12)	100 mA
±2 V	100 µV	2 µV	±(0.018 + 0.4)	±(0.01 + 0.14)	100 mA
±5 V	250 µV	5 µV	±(0.018 + 0.75)	±(0.009 + 0.25)	100 mA
±20 V	1 mV	20 µV	±(0.018 + 3)	±(0.009 + 0.9)	100 mA
±40 V	2 mV	40 µV	±(0.018 + 6)	±(0.01 + 1)	²
±100 V	5 mV	100 µV	±(0.018 + 15)	±(0.012 + 2.5)	²

1. ± (% of reading value + offset value in mV)

2. 100 mA ($V_o \leq 20$ V), 50 mA (20 V < $V_o \leq 40$ V), 20 mA (40 V < $V_o \leq 100$ V), V_o is the output voltage in V.

Current range, resolution, and accuracy (high resolution ADC)					
Current range	Force resolution	Measure resolution	Force accuracy ¹ ±(% + A + A)	Measure accuracy ¹ ±(% + A + A)	Maximum voltage
±1 nA	50 fA	10 fA	±(0.1 + 3E-13 + $V_o \times 1E-15$)	±(0.1 + 2E-13 + $V_o \times 1E-15$)	100 V
±10 nA	500 fA	10 fA	±(0.1 + 3E-12 + $V_o \times 1E-14$)	±(0.1 + 1E-12 + $V_o \times 1E-14$)	100 V
±100 nA	5 pA	100 fA	±(0.05 + 3E-11 + $V_o \times 1E-13$)	±(0.05 + 2E-11 + $V_o \times 1E-13$)	100 V
±1 µA	50 pA	1 pA	±(0.05 + 3E-10 + $V_o \times 1E-12$)	±(0.05 + 1E-10 + $V_o \times 1E-12$)	100 V
±10 µA	500 pA	10 pA	±(0.05 + 3E-9 + $V_o \times 1E-11$)	±(0.04 + 2E-9 + $V_o \times 1E-11$)	100 V
±100 µA	5 nA	100 pA	±(0.035 + 15E-9 + $V_o \times 1E-10$)	±(0.03 + 3E-9 + $V_o \times 1E-10$)	100 V
±1 mA	50 nA	1 nA	±(0.04 + 15E-8 + $V_o \times 1E-9$)	±(0.03 + 6E-8 + $V_o \times 1E-9$)	100 V
±10 mA	500 nA	10 nA	±(0.04 + 15E-7 + $V_o \times 1E-8$)	±(0.03 + 2E-7 + $V_o \times 1E-8$)	100 V
±100 mA	5 µA	100 nA	±(0.045 + 15E-6 + $V_o \times 1E-7$)	±(0.04 + 6E-6 + $V_o \times 1E-7$)	²

1. ± (% of reading value + fixed offset in A + proportional offset in A), V_o is the output voltage in V.

2. 100 V ($I_o \leq 20$ mA), 40 V (20 mA < $I_o \leq 50$ mA), 20 V (50 mA < $I_o \leq 100$ mA), I_o is the output current in A.

Voltage range, resolution, and accuracy (high speed ADC)					
Voltage range	Force resolution	Measure resolution	Force accuracy ¹ ±(% + mV)	Measure accuracy ¹ ±(% + mV)	Maximum current
±0.5 V	25 µV	25 µV	±(0.018 + 0.15)	±(0.01 + 0.25)	100 mA
±2 V	100 µV	100 µV	±(0.018 + 0.4)	±(0.01 + 0.7)	100 mA
±5 V	250 µV	250 µV	±(0.018 + 0.75)	±(0.01 + 2)	100 mA
±20 V	1 mV	1 mV	±(0.018 + 3)	±(0.01 + 4)	100 mA
±40 V	2 mV	2 mV	±(0.018 + 6)	±(0.015 + 8)	²
±100 V	5 mV	5 mV	±(0.018 + 15)	±(0.02 + 20)	²

1. ±(% of reading value + offset value in mV). Averaging is 128 samples in 1 PLC.

2. 100 mA ($V_o \leq 20$ V), 50 mA (20 V < $V_o \leq 40$ V), 20 mA (40 V < $V_o \leq 100$ V), V_o is the output voltage in V.

Current range, resolution, and accuracy (high speed ADC)					
Current range	Force resolution	Measure resolution	Force accuracy ¹ ±(% + A + A)	Measure accuracy ¹ ±(% + A + A)	Maximum voltage
±1 nA	50 fA	50 fA	±(0.1 + 3E-13 + $V_o \times 1E-15$)	±(0.25 + 3E-13 + $V_o \times 1E-15$)	100 V
±10 nA	500 fA	500 fA	±(0.1 + 3E-12 + $V_o \times 1E-14$)	±(0.25 + 2E-12 + $V_o \times 1E-14$)	100 V
±100 nA	5 pA	5 pA	±(0.05 + 3E-11 + $V_o \times 1E-13$)	±(0.1 + 2E-11 + $V_o \times 1E-13$)	100 V
±1 µA	50 pA	50 pA	±(0.05 + 3E-10 + $V_o \times 1E-12$)	±(0.1 + 2E-10 + $V_o \times 1E-12$)	100 V
±10 µA	500 pA	500 pA	±(0.05 + 3E-9 + $V_o \times 1E-11$)	±(0.05 + 2E-9 + $V_o \times 1E-11$)	100 V
±100 µA	5 nA	5 nA	±(0.035 + 15E-9 + $V_o \times 1E-10$)	±(0.05 + 2E-8 + $V_o \times 1E-10$)	100 V
±1 mA	50 nA	50 nA	±(0.04 + 15E-8 + $V_o \times 1E-9$)	±(0.04 + 2E-7 + $V_o \times 1E-9$)	100 V
±10 mA	500 nA	500 nA	±(0.04 + 15E-7 + $V_o \times 1E-8$)	±(0.04 + 2E-6 + $V_o \times 1E-8$)	100 V
±100 mA	5 µA	5 µA	±(0.045 + 15E-6 + $V_o \times 1E-7$)	±(0.1 + 2E-5 + $V_o \times 1E-7$)	²

1. ±(% of reading value + fixed offset in A + proportional offset in A), V_o is the output voltage in V.

2. 100 V ($I_o \leq 20$ mA), 40 V (20 mA < $I_o \leq 50$ mA), 20 V (50 mA < $I_o \leq 100$ mA), I_o is the output current in A.

Power consumption

Voltage source mode:	
Voltage range	Power
0.5 V	$20 \times I_c$ (W)
2 V	$20 \times I_c$ (W)
5 V	$20 \times I_c$ (W)
20 V	$20 \times I_c$ (W)
40 V	$40 \times I_c$ (W)
100 V	$100 \times I_c$ (W)

Where I_c is the current compliance setting.

Current source mode:	
Voltage compliance	Power
$V_c \leq 20$	$20 \times I_o$ (W)
$20 < V_c \leq 40$	$40 \times I_o$ (W)
$40 < V_c \leq 100$	$100 \times I_o$ (W)

Where V_c is the voltage compliance setting and I_o is output current.

MPSMU measurement and output range

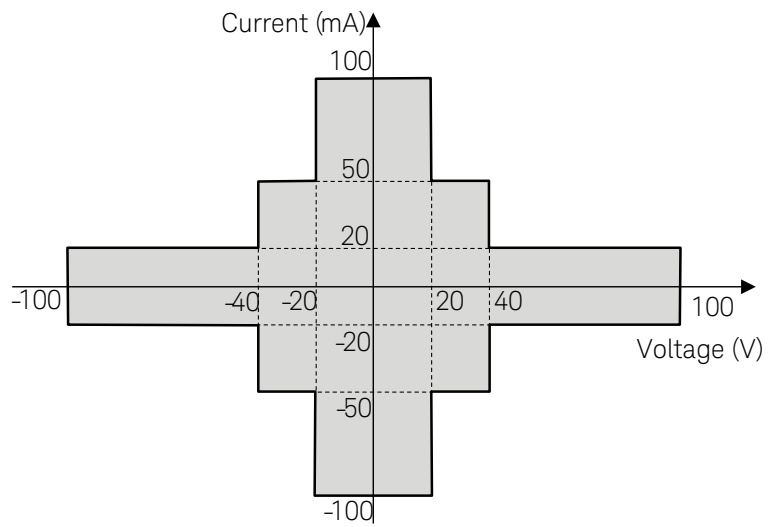

HCSMU Module Specifications

Voltage range, resolution, and accuracy					
Voltage range	Force resolution	Measure resolution	Force accuracy ¹ ±(% + mV + mV)	Measure accuracy ¹ (% + mV + mV)	Maximum current
±0.2 V	200 nV	200 nV	±(0.06 + 0.14 + I _o × 0.05)	±(0.06 + 0.14 + I _o × 0.05)	20 A
±2 V	2 μV	2 μV	±(0.06 + 0.6 + I _o × 0.5)	±(0.06 + 0.6 + I _o × 0.5)	20 A
±20 V	20 μV	20 μV	±(0.06 + 3 + I _o × 5)	±(0.06 + 3 + I _o × 5)	20 A
±40 V	40 μV	40 μV	±(0.06 + 3 + I _o × 10)	±(0.06 + 3 + I _o × 10)	1 A

1. ±(% of reading value + fixed offset in mV + proportional offset in mV). Note: I_o is the output current in A.

Current range, resolution, and accuracy					
Current range	Force resolution	Measure resolution	Force accuracy ¹ (% + A + A)	Measure accuracy ¹ (% + A + A)	Maximum voltage
±10 μA	10 pA	10 pA	±(0.06 + 2E-9 + V _o × 1E-10)	±(0.06 + 2E-9 + V _o × 1E-10)	40 V
±100 μA	100 pA	100 pA	±(0.06 + 2E-8 + V _o × 1E-9)	±(0.06 + 2E-8 + V _o × 1E-9)	40 V
±1 mA	1 nA	1 nA	±(0.06 + 2E-7 + V _o × 1E-8)	±(0.06 + 2E-7 + V _o × 1E-8)	40 V
±10 mA	10 nA	10 nA	±(0.06 + 2E-6 + V _o × 1E-7)	±(0.06 + 2E-6 + V _o × 1E-7)	40 V
±100 mA	100 nA	100 nA	±(0.06 + 2E-5 + V _o × 1E-6)	±(0.06 + 2E-5 + V _o × 1E-6)	40 V
±1 A	1 μA	1 μA	±(0.4 + 2E-4 + V _o × 1E-5)	±(0.4 + 2E-4 + V _o × 1E-5)	40 V
±20 A ²	20 μA	20 μA	±(0.4 + 2E-3 + V _o × 1E-4)	±(0.4 + 2E-3 + V _o × 1E-4)	20 V

1. ±(% of reading value + fixed offset in A + proportional offset in A), V_o is the output voltage in V.

2. Pulse mode only. The maximum value of the base current during pulsing is ±100 mA.

Power consumption

Voltage source mode:	
Voltage range	Power
0.2 V	40 × I _c (W)
2 V	40 × I _c (W)
40 V	40 × I _c (W)

Where I_c is the current compliance setting.

For pulse current, I_c = (duty) × I_{pulse}

Current source mode:	
Voltage compliance	Power
V _c ≤ 0.2	40 × I _o (W)
0.2 < V _c ≤ 2	40 × I _o (W)
2 < V _c ≤ 40	40 × I _o (W)

Where V_c is the voltage compliance setting and I_o is output current.

For pulse current, I_o = (duty) × I_{pulse}

Current range expansion

If two HCSMUs are combined using the Dual HCSMU combination adapter or the Dual HCSMU Kelvin combination adapter, then the maximum current ranges are 40 A (Pulsed) and 2 A (DC).

HCSMU measurement and output range

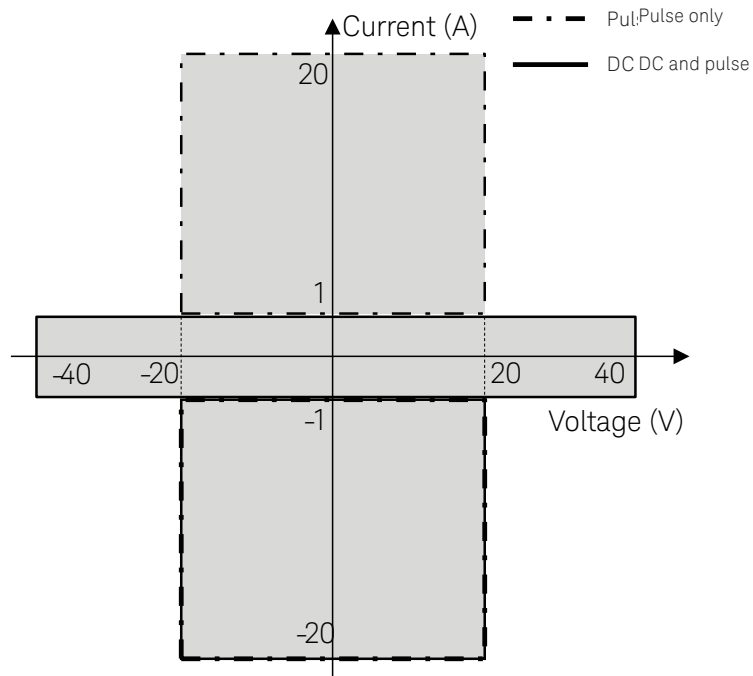

HVSMU Module Specifications

Voltage range, resolution, and accuracy						
Voltage range	Force resolution	Measure resolution	Force accuracy ¹ ±(% + mV)	Measure accuracy ¹ ±(% + mV)	Maximum current	
±200 V	200 μV	200 μV	±(0.03 + 40)	±(0.03 + 40)	8 mA	
±500 V	500 μV	500 μV	±(0.03 + 100)	±(0.03 + 100)	8 mA	
±1500 V	1.5 mV	1.5 mV	±(0.03 + 300)	±(0.03 + 300)	8 mA	
±3000 V	3 mV	3 mV	±(0.03 + 600)	±(0.03 + 600)	4 mA	

1. ±(% of reading value + offset voltage in V)

Current range, resolution, and accuracy						
Current range	Force resolution	Measure resolution	Force accuracy ¹ ±(% + A + A)	Measure accuracy ¹ ±(% + A + A)	Maximum voltage	Minimum set current ²
±1 nA	10 fA	10 fA	±(0.1 + 6E-13 + Vo x 1E-15)	±(0.1 + 6E-13 + Vo x 1E-15)	3000 V	1pA
±10 nA	100 fA	100 fA	±(0.1 + 25E-13 + Vo x 1E-15)	±(0.1 + 25E-13 + Vo x 1E-15)	3000 V	1pA
±100 nA	100 fA	100 fA	±(0.05 + 25E-12 + Vo x 1E-13)	±(0.05 + 25E-12 + Vo x 1E-13)	3000 V	100 pA
±1 μA	1 pA	1 pA	±(0.05 + 1E-10 + Vo x 1E-13)	±(0.05 + 1E-10 + Vo x 1E-13)	3000 V	100 pA
±10 μA	10 pA	10 pA	±(0.04 + 2E-9 + Vo x 1E-11)	±(0.04 + 2E-9 + Vo x 1E-11)	3000 V	10 nA
±100 μA	100 pA	100 pA	±(0.03 + 3E-9 + Vo x 1E-11)	±(0.03 + 3E-9 + Vo x 1E-11)	3000 V	10 nA
±1 mA	1 nA	1 nA	±(0.03 + 6E-8 + Vo x 1E-10)	±(0.03 + 6E-8 + Vo x 1E-10)	3000 V	100 nA
±10 mA	10 nA	10 nA	±(0.03 + 2E-7 + Vo x 1E-9)	±(0.03 + 2E-7 + Vo x 1E-9)	1500 V	1 μA

1. ±(% of reading value + fixed offset in A + proportional offset in A), Vo is the output voltage in V.

2. Output current needs to be set more than current shown in the table.

Power consumption

Voltage source mode:	
Current compliance	Power
$I_c \leq 4 \text{ m}$	$3000 \times I_c + 12 \text{ (W)}^1$
$4 \text{ m} < I_c \leq 8 \text{ m}$	$1500 \times I_c + 12 \text{ (W)}^1$

Where I_c is the current compliance setting.

Current source mode:	
Voltage compliance	Power
$V_c \leq 1500$	$1500 \times I_o \text{ (W)} + 12^1$
$1500 < V_c \leq 3000$	$3000 \times I_o \text{ (W)} + 12^1$

Where V_c is the voltage compliance setting and I_o is output current.

1. The "+ 12" factor does not apply to the first installed HVSMU; it only applies to the second thru fifth installed HVSMUs.

HVSMU measurement and output range

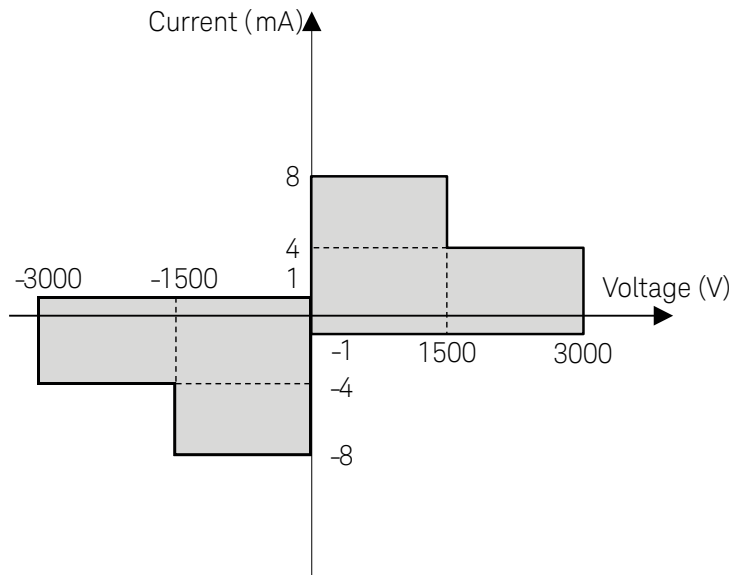

HVSMU has 3 output range settings, which are "0 to +3 kV", "-1500 V to +1500 V", and "0 to -3 kV". If more than one HVSMU is installed in the B1505A, all of the HVSMUs must use the same output range setting.

MCSMU Module Specifications

Voltage range, resolution, and accuracy					
Voltage range	Force resolution	Measure resolution	Force accuracy ¹ ±(% + mV)	Measure accuracy ¹ (% + mV)	Maximum current
±0.2 V	200 nV	200 nV	±(0.06 + 0.14)	±(0.06 + 0.14)	1 A
±2 V	2 μV	2 μV	±(0.06 + 0.6)	±(0.06 + 0.6)	1 A
±20 V	20 μV	20 μV	±(0.06 + 3)	±(0.06 + 3)	1 A
±40 V ²	40 μV	40 μV	±(0.06 + 3)	±(0.06 + 3)	1 A

1. ±(% of reading value + fixed offset in mV).
2. Maximum output voltage is 30 V.

Current range, resolution, and accuracy					
Current range	Force resolution	Measure resolution	Force accuracy ¹ (% + A + A)	Measure accuracy ¹ (% + A + A)	Maximum voltage
±10 μA	10 pA	10 pA	±(0.06 + 2E-9 + Vo x 1E-10)	±(0.06 + 2E-9 + Vo x 1E-10)	30 V
±100 μA	100 pA	100 pA	±(0.06 + 2E-8 + Vo x 1E-9)	±(0.06 + 2E-8 + Vo x 1E-9)	30 V
±1 mA	1 nA	1 nA	±(0.06 + 2E-7 + Vo x 1E-8)	±(0.06 + 2E-7 + Vo x 1E-8)	30 V
±10 mA	10 nA	10 nA	±(0.06 + 2E-6 + Vo x 1E-7)	±(0.06 + 2E-6 + Vo x 1E-7)	30 V
±100 mA	100 nA	100 nA	±(0.06 + 2E-5 + Vo x 1E-6)	±(0.06 + 2E-5 + Vo x 1E-6)	30 V
±1 A ²	1 μA	1 μA	±(0.4 + 2E-4 + Vo x 1E-5)	±(0.4 + 2E-4 + Vo x 1E-5)	30 V

1. ±(% of reading value + fixed offset in A + proportional offset in A), Vo is the output voltage in V.
2. Pulse mode only. The maximum value of the base current during pulsing is ±50 mA.

Power consumption

Voltage source mode:	
Voltage range	Power
0.2 V	40 x Ic (W)
2 V	40 x Ic (W)
40 V	40 x Ic (W)

Where Ic is the current compliance setting.

Current source mode:	
Voltage compliance	Power
Vc ≤ 0.2	40 x Io (W)
0.2 < Vc ≤ 2	40 x Io (W)
2 < Vc ≤ 40	40 x Io (W)

Where Vc is the voltage compliance setting and Io is output current.

MCSMU measurement and output range

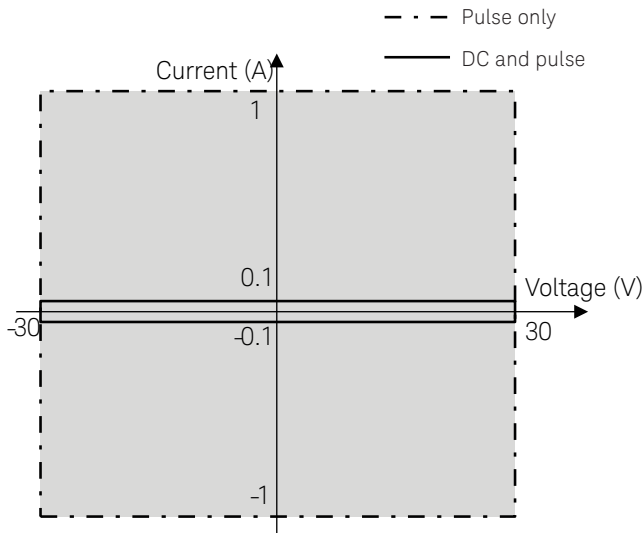

SMU source measurement mode

For HPSMU and MPSMU:

VFIM, IFVM

For HCSMU, MCSMU and HVSMU:

VFIM, VFVM, IFVM, IFIM

Output terminal/connection:

For HPSMU and MPSMU:

Dual triaxial connector,
Kelvin (remote sensing)

For HCSMU:

Triaxial connector (for sense) and coaxial
connector (for force)
Kelvin (remote sensing)

For MCSMU:

Dual triaxial connector, Kelvin
(remote sensing)

For HVSMU:

High voltage triaxial connector, non-Kel-
vin

Voltage/current compliance (limiting)

The SMU can limit output voltage or current to prevent damaging the device under test.

Voltage:

0 V to ± 200 V (HPSMU)
0 V to ± 100 V (MPSMU)
0 V to ± 40 V (HCSMU)
0 V to ± 30 V (MCSMU)
0 V to ± 3000 V (HVSMU)

Current:

± 1 pA to ± 1 A (HPSMU)
 ± 1 pA to ± 100 mA (MPSMU)
 ± 10 nA to ± 20 A (HCSMU)
 ± 10 nA to ± 1 A (MCSMU)
 ± 1 pA to ± 8 mA (HVSMU)

Compliance accuracy:

Same as the current or voltage set accuracy.

Power compliance

For HPSMU:

Power: 0.001 W to 20 W
Resolution: 0.001 W

For MPSMU:

Power: 0.001 W to 2 W
Resolution: 0.001 W

For HCSMU:

Power: 0.001 W to 40 W (DC)
0.001 W to 400 W (Pulse)
Resolution: 0.001 W

For MCSMU:

Power: 0.001 W to 3 W (DC)
0.001 W to 30 W (Pulse)
Resolution: 0.001 W

For HVSMU:

No power compliance

SMU pulse measurement

Pulse width, period, and delay:

For HPSMU and MPSMU:

Pulse width: 500 μ s to 2 s
Pulse width resolution: 100 μ s
Pulse period: 5 ms to 5 s
Period \geq delay + width + 2 ms (when
delay + width \leq 100 ms)
Period \geq delay + width + 10 ms (when
delay + width > 100 ms)
Pulse period resolution: 100 μ s
Pulse delay: 0 s

For HCSMU:

Pulse width:
50 μ s to 1 ms (20 A range)
50 μ s to 2 s (10 μ A to 1 A range)
Pulse width resolution: 2 μ s
Pulse period: 5 ms to 5 s
Pulse period resolution: 100 μ s
Pulse duty:
For 20 A range: \leq 1%
For 10 μ A to 1 A range
Period \geq delay + width + 2 ms (when
delay + width \leq 100 ms)
Period \geq delay + width + 10 ms
(when delay + width > 100 ms)
Pulse delay: 0 to (Period-width)

For MCSMU:

Pulse width:
10 μ s to 100 ms (1 A range)
10 μ s to 2 s (10 μ A to 100 mA range)

Pulse width resolution: 2 μ s
Pulse period: 5 ms to 5 s
Pulse period resolution: 100 μ s
Pulse duty:

For 1 A range: \leq 5%
For 10 μ A to 100 mA range
Period \geq delay + width + 2 ms
(when delay + width \leq 100 ms)
Period \geq delay + width + 10 ms
(when delay + width > 100 ms)
Pulse delay: 0 to (Period-width)

For HVSMU:

Pulse width: 500 μ s to 2 s
Pulse width resolution: 2 μ s
Pulse period: 5 ms to 5 s
Period \geq delay + width + 2 ms (when
delay + width \leq 100 ms)
Period \geq delay + width + 10 ms (when
delay + width > 100 ms)
Pulse period resolution: 100 μ s
Pulse delay: 0 to (Period - width)
Pulse output limitation:
When the pulse voltage is more than
1500 V, the peak and base of pulse
should be same polarities.
Pulse measurement delay:
2 μ s to (Period - pulse
measurement time - 2 m) s,
2 μ s resolution

Supplemental Characteristics

Current compliance setting accuracy (for opposite polarity):

For HPSMU and MPSMU:

For 1 pA to 10 nA ranges:
V/I setting accuracy $\pm 12\%$ of range
For 100 nA to 1 A ranges:
V/I setting accuracy $\pm 2.5\%$ of range

For HCSMU and MCSMU:

For 10 μ A to 1 A ranges:
V/I setting accuracy $\pm 2.5\%$ of range
For 20 A range (HCSMU):
V/I setting accuracy $\pm 0.6\%$ of range

For HVSMU:

For 1 nA to 10 nA ranges:
V/I setting accuracy $\pm 12\%$ of range
For 100 nA to 10 mA ranges:
V/I setting accuracy $\pm 2.5\%$ of range

SMU pulse setting accuracy (fixed measurement range):

For HPSMU and MPSMU:

Width: $\pm 0.5\% \pm 50 \mu\text{s}$
Period: $\pm 0.5\% \pm 100 \mu\text{s}$

For HCSMU and MCSMU:

Width: $\pm 0.1\% \pm 2 \mu\text{s}$
Period: $\pm 0.1\% \pm 100 \mu\text{s}$

For HVSMU:

Width: $\pm 0.1\% \pm 2 \mu\text{s}$
Period: $\pm 0.5\% \pm 100 \mu\text{s}$

Minimum pulse measurement time:

16 μs (HPSMU and MPSMU)
2 μs (HCSMU and MCSMU)
6 μs (HVSMU)

Voltage source output resistance:

(Force line, non-Kelvin connection)
0.2 Ω (HPSMU)
0.3 Ω (MPSMU)
3 Ω (HVSMU, at 10 mA range)

Voltage measurement input resistance:

$\geq 10^{13} \Omega$ (HPSMU, MPSMU)
 $\geq 10^9 \Omega$ (HCSMU, MCSMU, $\leq 1 \text{ A}$),
80 k Ω (HCSMU, 20 A)
 $\geq 10^{12} \Omega$ (HVSMU)

Current source output resistance:

$\geq 10^{13} \Omega$ (HPSMU, MPSMU)
 $\geq 10^9 \Omega$ (HCSMU, MCSMU, $\leq 1 \text{ A}$),
80 k Ω (HCSMU, 20 A)
 $\geq 10^{12} \Omega$ (HVSMU, at 10 nA range)

Maximum allowable cable resistance:

(Kelvin connection)

For HPSMU and MPSMU:

Sense: 10 Ω
Force: 10 Ω ($\leq 100 \text{ mA}$),
1.5 Ω ($> 100 \text{ mA}$)

For HCSMU:

Sense: 10 Ω
Force: 0.6 Ω
(with Low Force)

For MCSMU:

Sense: 10 Ω
Force : 1 Ω
(with Low Force)

Maximum allowable inductance:

For HCSMU and MCSMU:

Force 3 μH
(with Low Force (shield))

Maximum load capacitance:

For HPSMU and MPSMU:

1 pA to 10 nA ranges: 1000 pF
100 nA to 10 mA ranges: 10 nF
100 mA and 1 A ranges: 100 μF

For HCSMU:

10 μA to 10 mA ranges: 12 nF
100 mA to 20 A ranges: 100 μF

For MCSMU:

10 μA to 10 mA range : 12 nF
100 mA to 1 A range : 100 μF

For HVSMU:

1 nA to 1 μA ranges: 1000 pF
10 μA to 10 mA ranges: 10 nF

Maximum guard capacitance:

900 pF (HPSMU and MPSMU)
1500 pF (HVSMU)

Maximum shield capacitance:

5000 pF (HPSMU, MPSMU and HVSMU)

Noise characteristics:

For HPSMU, MPSMU and
HVSMU (Filter ON for HPSMU
and MPSMU.)

Voltage source:
0.01% of V range (rms.)
Current source:
0.1% of I range (rms.)

For HCSMU

Voltage/Current source:
100 mV (0 to peak) max

For MCSMU

Voltage / Current source:
200 mV (0 to peak) max

Overshoot:

(Filter ON for all SMUs)

For HPSMU and MPSMU

Voltage source: 0.03% of V range
Current source: 1% of I range

For HCSMU and MCSMU
(filter ON)

Voltage/Current source:
10% of range

For HVSMU

Voltage source: 1 V (resistive load)
Current source: 1% of I range

Range switching transient noise:

For HPSMU and MPSMU
(filter ON):

Voltage ranging: 250 mV
Current ranging: 70 mV

For HCSMU and MCSMU:

10 μA to 1 A ranges:
Voltage ranging: 250 mV
Current ranging: 70 mV
20 A ranges:
Voltage ranging: 5 V max

For HVSMU:

Voltage ranging: 300 mV
Current ranging: 300 mV

Maximum guard offset voltage:

$\pm 1 \text{ mV}$ (HPSMU)
 $\pm 3 \text{ mV}$ (MPSMU)
 $\pm 5 \text{ mV}$ (HVSMU)

Maximum slew rate:

0.2 V/ μs (HPSMU and MPSMU)
1 V/ μs (HCSMU and MCSMU)
0.4 V/ μs (HVSMU)

Output settling time

For HVSMU:

Output settling time: 500 μs
To reach 0.01% of settling value.
Conditions:
100 V step, 8 mA compliance,
1000 pF load capacitance

MFCMU (multi frequency capacitance measurement unit) module specifications

Measurement functions

Measurement parameters:

Cp-G, Cp-D, Cp-Q, Cp-Rp, Cs-Rs, Cs-D, Cs-Q, Lp-G, Lp-D, Lp-Q, Lp-Rp, Ls-Rs, Ls-D, Ls-Q, R-X, G-B, Z- θ , Y- θ

Ranging:

Auto and fixed

Measurement terminal:

Four-terminal pair configuration, four BNC (female) connectors

Cable length:

1.5 m or 3 m, automatic identification of accessories

Test signal

Frequency:

Range: 1 kHz to 5 MHz
Resolution: 1 mHz (minimum)
Accuracy: $\pm 0.008\%$

Output signal level:

Range: 10 mV_{rms} to 250 mV_{rms}
Resolution: 1 mV_{rms}
Accuracy:
 $\pm(10.0\% + 1 \text{ mV}_{\text{rms}})$ at the measurement port of the MFCMU
 $\pm(15.0\% + 1 \text{ mV}_{\text{rms}})$ at the measurement port of MFCMU cable (1.5 m or 3 m)

Output impedance: 50 Ω , typical

Signal level monitor:

Range: 10 mV_{rms} to 250 mV_{rms}
Accuracy:
 $\pm(10.0\% \text{ of reading} + 1 \text{ mV}_{\text{rms}})$ at the measurement port of the MFCMU
 $\pm(15.0\% + 1 \text{ mV}_{\text{rms}})$ at the measurement port of MFCMU cable (1.5 m or 3 m)

DC bias function

DC bias:

Range: 0 to $\pm 25 \text{ V}$
Resolution: 1 mV
Accuracy: $\pm(0.5\% + 5.0 \text{ mV})$ at the measurement port or the MFCMU or the MFCMU cable (1.5 m/3 m)

Maximum DC bias current (Supplemental characteristics):

Impedance measurement range	Maximum DC bias current
50 Ω	10 mA
100 Ω	10 mA
300 Ω	10 mA
1 k Ω	1 mA
3 k Ω	1 mA
10 k Ω	100 μA
30 k Ω	100 μA
100 k Ω	10 μA
300 k Ω	10 μA

Output impedance: 50 Ω , typical
DC bias monitor:
Range: 0 to $\pm 25 \text{ V}$
Accuracy (open load): $\pm(0.2\% \text{ of reading} + 10.0 \text{ mV})$ at the measurement port or the MFCMU cable (1.5 m/3 m)

Sweep characteristics

Available sweep parameters:

Oscillator level, DC bias voltage, frequency

Sweep type: linear, log

Sweep mode: single, double

Sweep direction: up, down

Number of measurement points:

Maximum 1001 points

Measurement accuracy

The following parameters are used to express the impedance measurement accuracy at the measurement port of the MFCMU or the MFCMU cable (1.5 m or 3 m).

Z_x : Impedance measurement value (Ω)

D_x : Measurement value of D

$$E = E_P' + (Z_S' / |Z_x| + Y_O' |Z_x|) \times 100 (\%)$$

$$E_P' = E_{PL} + E_{POSC} + E_P (\%)$$

$$Y_O' = Y_{OL} + Y_{OSC} + Y_O (\text{S})$$

$$Z_S' = Z_{SL} + Z_{OSC} + Z_S (\Omega)$$

$|Z|$ accuracy
 $\pm E (\%)$

θ accuracy
 $\pm E / 100 (\text{rad})$

C accuracy
at $D_x \leq 0.1$
 $\pm E (\%)$

$$\text{at } D_x > 0.1 \\ \pm E \times \sqrt{(1 + D_x^2)} (\%)$$

D accuracy
at $D_x \leq 0.1$
 $\pm E / 100$

$$\text{at } D_x > 0.1 \\ \pm E \times (1 + D_x) / 100$$

G accuracy
at $D_x \leq 0.1$
 $\pm E / D_x (\%)$

$$\text{at } D_x > 0.1 \\ \pm E \times \sqrt{(1 + D_x^2)} / D_x (\%)$$

Note: measurement accuracy is specified under the following conditions:

Temperature: $23 \pm 5 \text{ }^\circ\text{C}$

Integration time: 1 PLC

Parameters E_{POSC} Z_{OSc}		
Oscillator level	EP_{OSc} (%)	Z_{OSc} (m Ω)
125 mV < $V_{\text{OSc}} \leq 250$ mV	$0.03 \times (250/V_{\text{OSc}} - 1)$	$5 \times (250/V_{\text{OSc}} - 1)$
64 mV < $V_{\text{OSc}} \leq 125$ mV	$0.03 \times (125/V_{\text{OSc}} - 1)$	$5 \times (125/V_{\text{OSc}} - 1)$
32 mV < $V_{\text{OSc}} \leq 64$ mV	$0.03 \times (64/V_{\text{OSc}} - 1)$	$5 \times (64/V_{\text{OSc}} - 1)$
$V_{\text{OSc}} \leq 32$ mV	$0.03 \times (32/V_{\text{OSc}} - 1)$	$5 \times (64/V_{\text{OSc}} - 1)$

V_{OSc} is oscillator level in mV.

Parameters E_{PL} Y_{OL} Z_{SL}			
Cable length	E_{PL} (%)	Y_{OL} (nS)	Z_{SL} (m Ω)
1.5 m	$0.02 + 3 \times f/100$	$750 \times f/100$	5.0
3 m	$0.02 + 5 \times f/100$	$1500 \times f/100$	5.0

f is frequency in MHz. If measurement cable is extended, open compensation, short compensation, and load compensation must be performed.

Parameters Y_{OSc} Y_0 E_p Z_s				
Frequency	Y_{OSc} (nS)	Y_0 (nS)	E_p (%)	Z_s (m Ω)
1 kHz $\leq f \leq 200$ kHz	$1 \times (125/V_{\text{OSc}} - 0.5)$	1.5	0.095	5.0
200 kHz < $f \leq 1$ MHz	$2 \times (125/V_{\text{OSc}} - 0.5)$	3.0	0.095	5.0
1 MHz < $f \leq 2$ MHz	$2 \times (125/V_{\text{OSc}} - 0.5)$	3.0	0.28	5.0
2 MHz < f	$20 \times (125/V_{\text{OSc}} - 0.5)$	30.0	0.28	5.0

f is frequency in Hz.

V_{OSc} is oscillator level in mV.

Example of calculated C/G measurement accuracy				
Frequency	Measured capacitance	C accuracy ¹	Measured conductance	G accuracy ¹
5 MHz	1 pF	$\pm 0.61\%$	$\leq 3 \mu\text{S}$	± 192 nS
	10 pF	$\pm 0.32\%$	$\leq 31 \mu\text{S}$	± 990 nS
	100 pF	$\pm 0.29\%$	$\leq 314 \mu\text{S}$	$\pm 9 \mu\text{S}$
	1 nF	$\pm 0.32\%$	≤ 3 mS	$\pm 99 \mu\text{S}$
1 MHz	1 pF	$\pm 0.26\%$	≤ 628 nS	± 16 nS
	10 pF	$\pm 0.11\%$	$\leq 6 \mu\text{S}$	± 71 nS
	100 pF	$\pm 0.10\%$	$\leq 63 \mu\text{S}$	± 624 nS
	1 nF	$\pm 0.10\%$	$\leq 628 \mu\text{S}$	$\pm 7 \mu\text{S}$
100 kHz	10 pF	$\pm 0.18\%$	≤ 628 nS	± 11 nS
	100 pF	$\pm 0.11\%$	$\leq 6 \mu\text{S}$	± 66 nS
	1 nF	$\pm 0.10\%$	$\leq 63 \mu\text{S}$	± 619 nS
	10 nF	$\pm 0.10\%$	$\leq 628 \mu\text{S}$	$\pm 7 \mu\text{S}$
10 kHz	100 pF	$\pm 0.18\%$	≤ 628 nS	± 11 nS
	1 nF	$\pm 0.11\%$	$\leq 6 \mu\text{S}$	± 66 nS
	10 nF	$\pm 0.10\%$	$\leq 63 \mu\text{S}$	± 619 nS
	100 nF	$\pm 0.10\%$	$\leq 628 \mu\text{S}$	$\pm 7 \mu\text{S}$
1 kHz	100 pF	$\pm 0.92\%$	≤ 63 nS	± 6 nS
	1 nF	$\pm 0.18\%$	≤ 628 nS	± 11 nS
	10 nF	$\pm 0.11\%$	$\leq 6 \mu\text{S}$	± 66 nS
	100 nF	$\pm 0.10\%$	$\leq 63 \mu\text{S}$	± 619 nS

1. The capacitance and conductance measurement accuracy is specified under the following conditions:

$D_x \leq 0.1$

Integration time: 1 PLC

Test signal level: 30 mV_{rms}

At four-terminal pair port of MFCMU

Device Capacitance Selector (N1272A) specification

The N1272A simplifies 2 and 3 terminal device capacitance measurements by automatically creating the correct configuration of test resources (including adding any needed DC blocking capacitors and AC blocking resistors) for a specified capacitance measurement. To measure packaged device capacitance the N1273A Capacitance Test Fixture is also necessary. However, the N1272A can be used directly with a probe station to measure on-wafer device capacitances.

DC bias characteristics

100 k Ω at SMU bias output resistance
Voltage drop compensation function is available.

Bypass capacitance in the capacitance selector

	Capacitance	Withstand voltage
Drain to source terminal	1 μ F	\pm 3000 V
Gate to source terminal	1 μ F	\pm 100 V

Measurement accuracy for 2-terminal device (Supplemental characteristics)

The accuracy of the supplemental characteristics is defined at the output terminals of the TO socket adapter in the N1273A Capacitance Test Fixture when the N1272A is connected to B1505A with the 1.5 m CMU cable and the N1273A system cable.

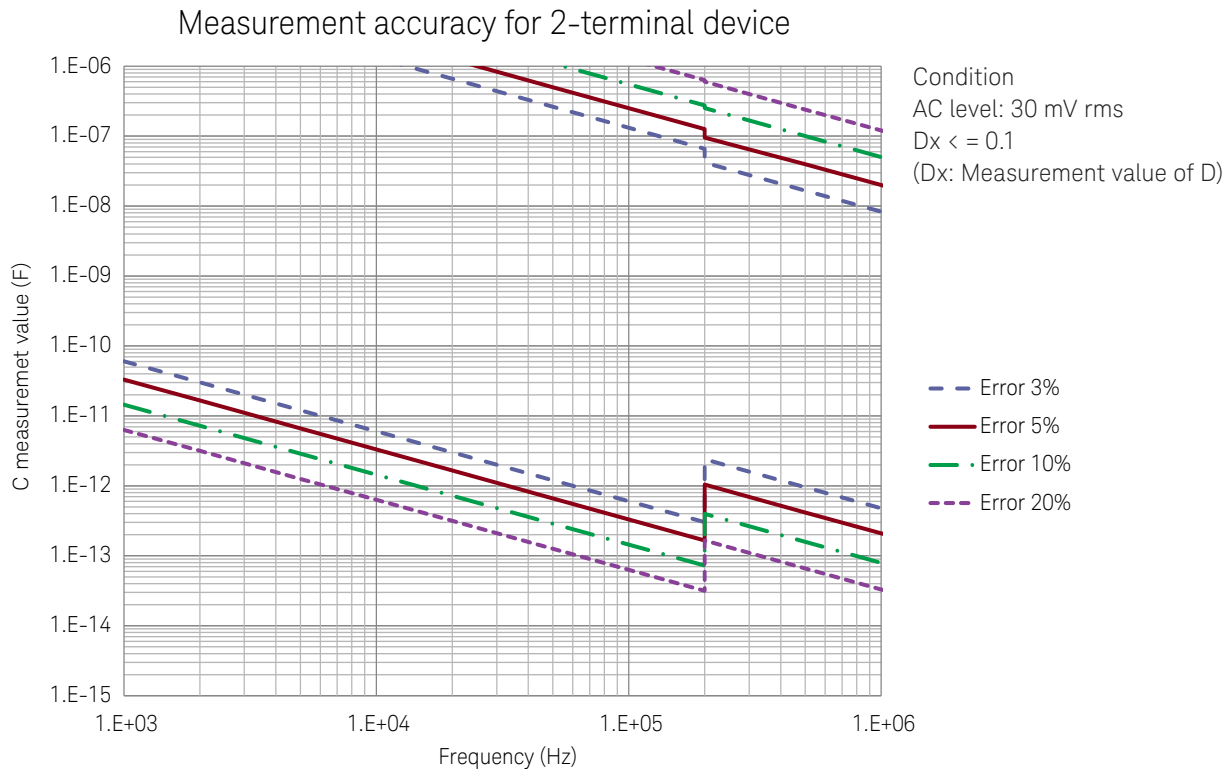

Output terminals for 2-terminal device

Collector/drain	High	High	
Emitter/source		Low	High
Base/gate	Low		Low

Measurement accuracy for 3-terminal device (Supplemental characteristics)

Accuracy of this supplemental characteristics is defined at the output terminals at the TO socket adapter in the N1273A Capacitance Test Fixture when N1272A is connected to B1505A with CMU 1.5 m cable and to the N1273A with system cable.

Condition

AC level: 30 mV rms, $D_x < 0.1$ (D_x : Measurement value of D)

Cgs measurement accuracy 3-terminal
Cgs:Cds:Cgd= 1:1:1

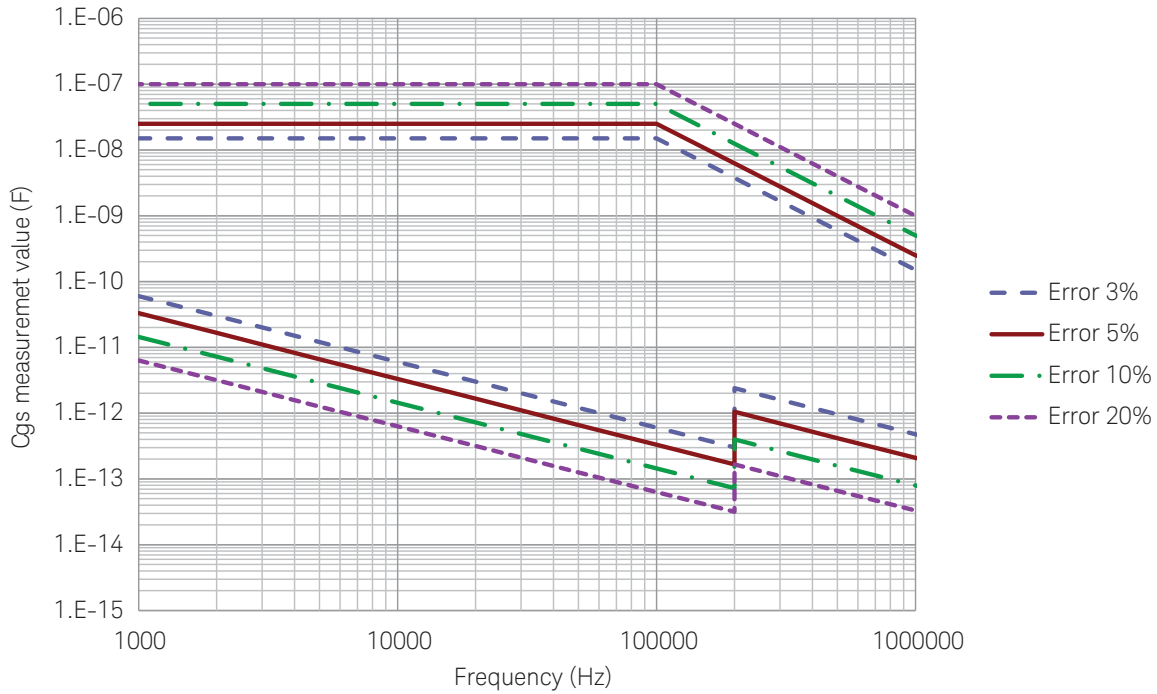

Cgs measurement accuracy 3-terminal
Cgs:Cds:Cgd= 1:0.1:0.01

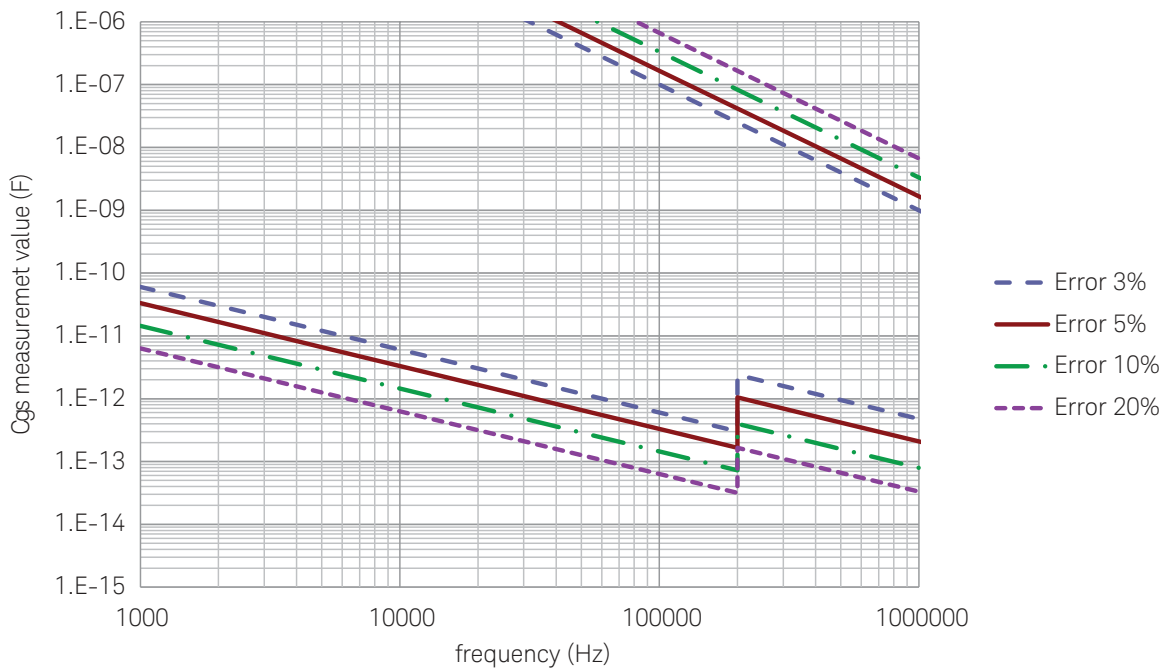

Cds measurement accuracy 3-terminal
 $C_{gs}:C_{ds}:C_{gd} = 1:1:1$

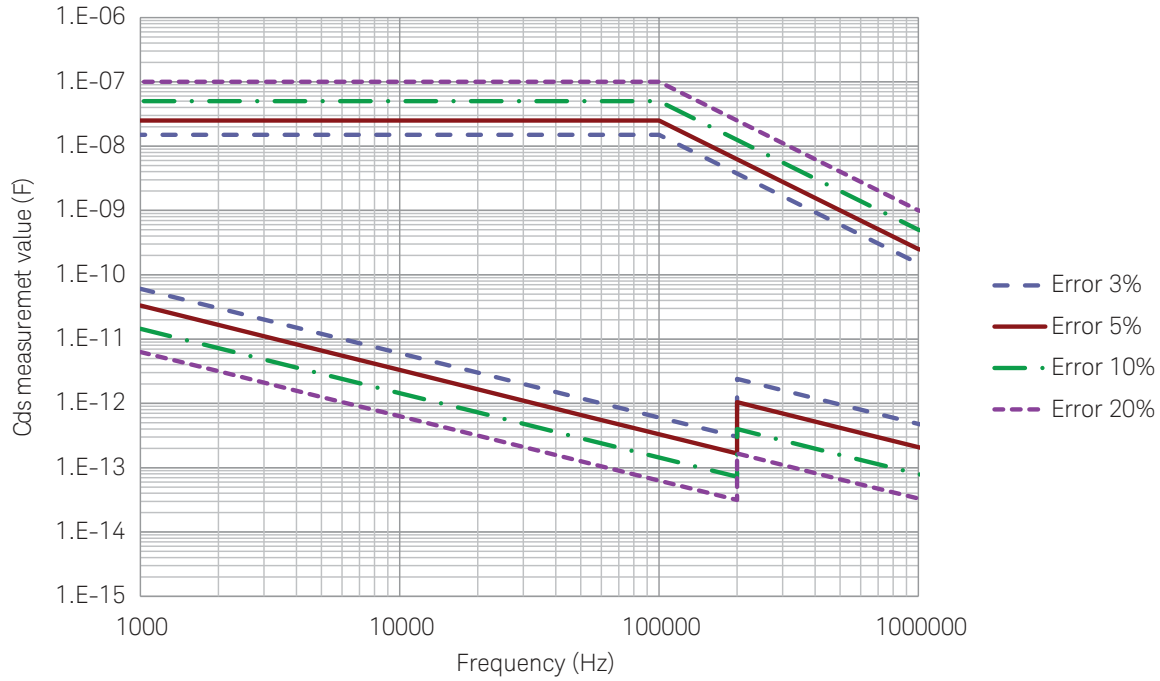

Cds measurement accuracy 3-terminal
 $C_{gs}:C_{ds}:C_{gd} = 1:0.1:0.01$

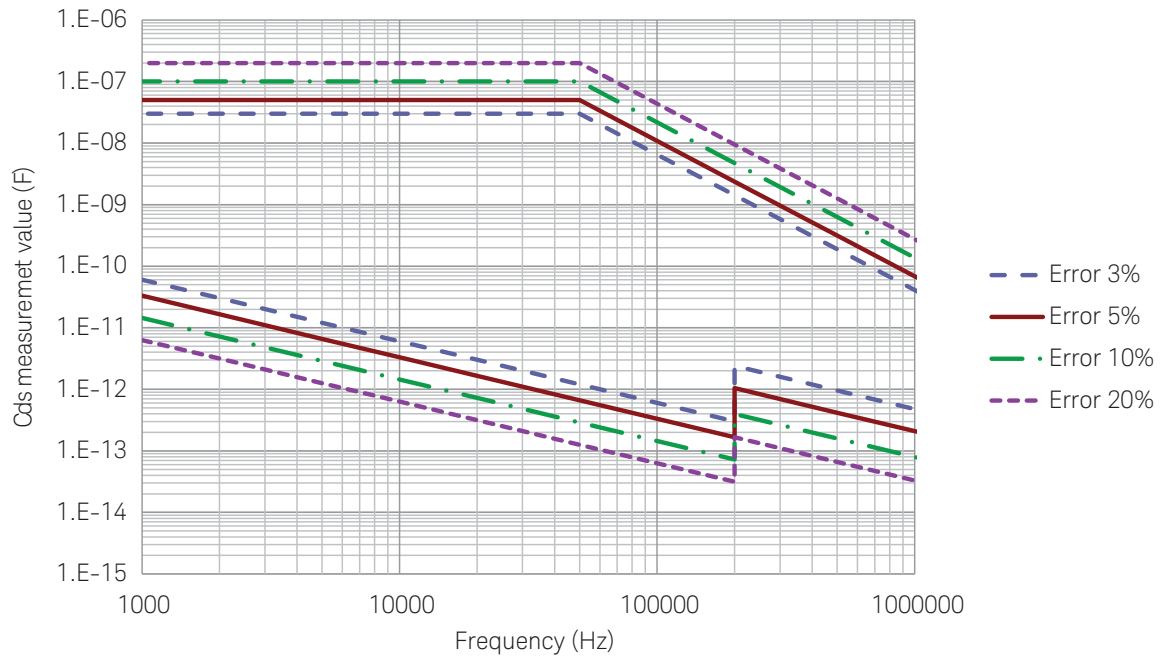

Cgd measurement accuracy 3-terminal
 Cgs:Cds:Cgd = 1:1:1

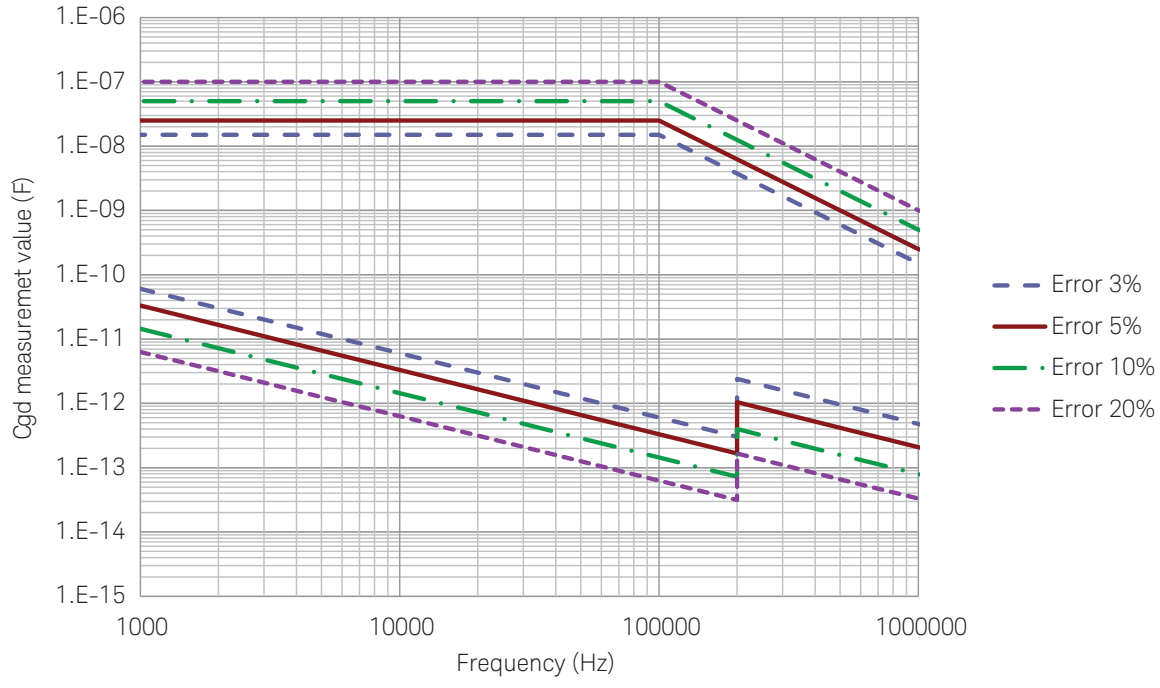

Cgd measurement accuracy 3-terminal
 Cgs:Cds:Cgd = 1:0.1:0.01

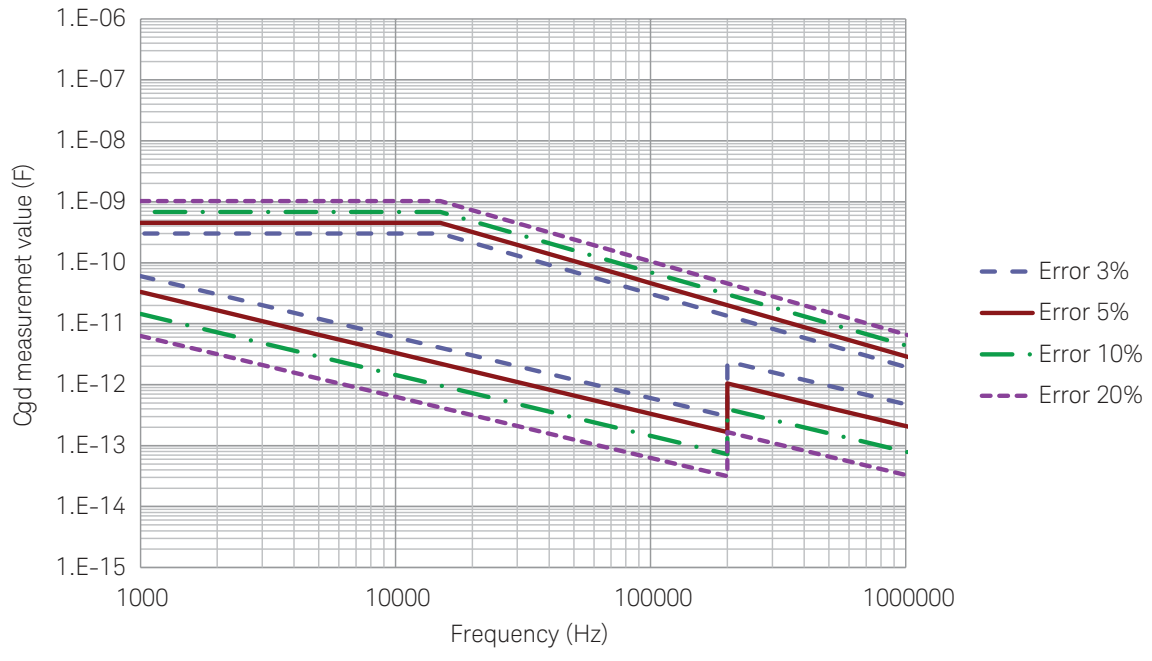

Ciss measurement accuracy 3-terminal
 $C_{gs}:C_{ds}:C_{gd} = 1:1:1$

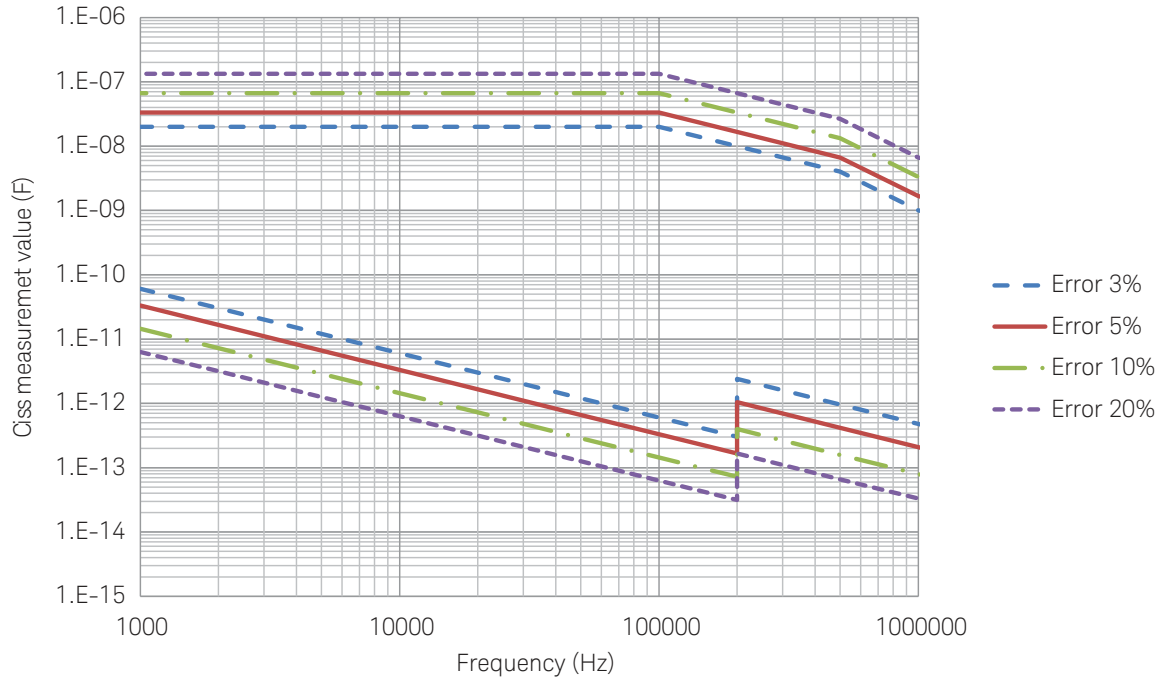

Ciss measurement accuracy 3-terminal
 $C_{gs}:C_{ds}:C_{gd} = 1:0.1:0.01$

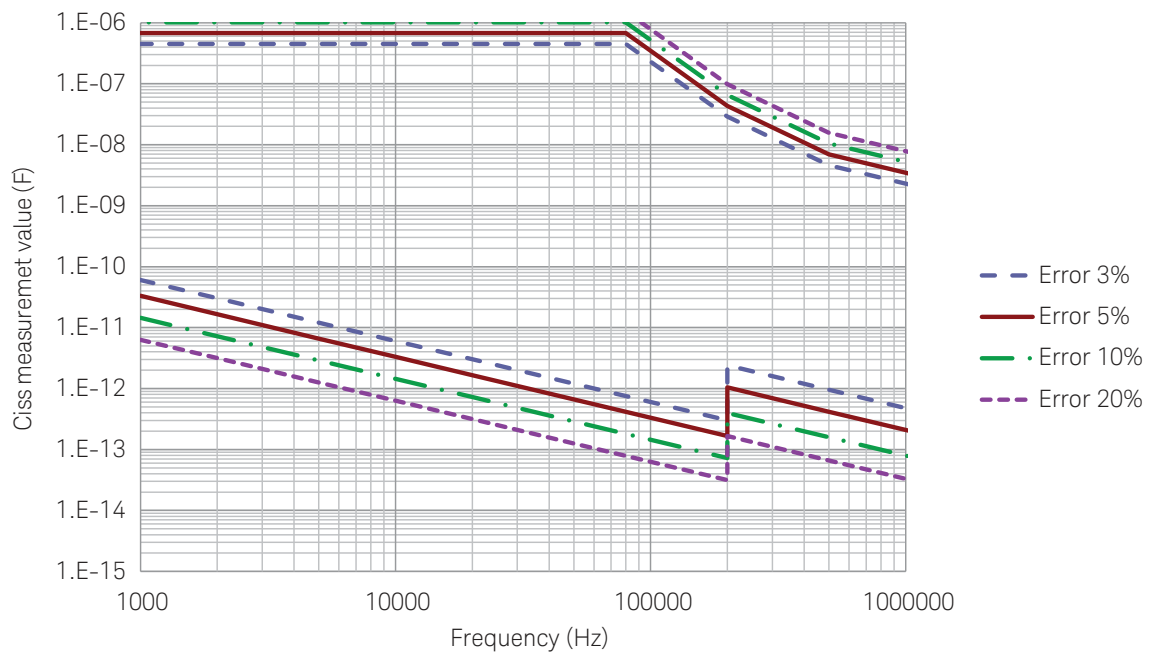

Coss measurement accuracy 3-terminal
 $C_{gs}:C_{ds}:C_{gd} = 1:1:1$

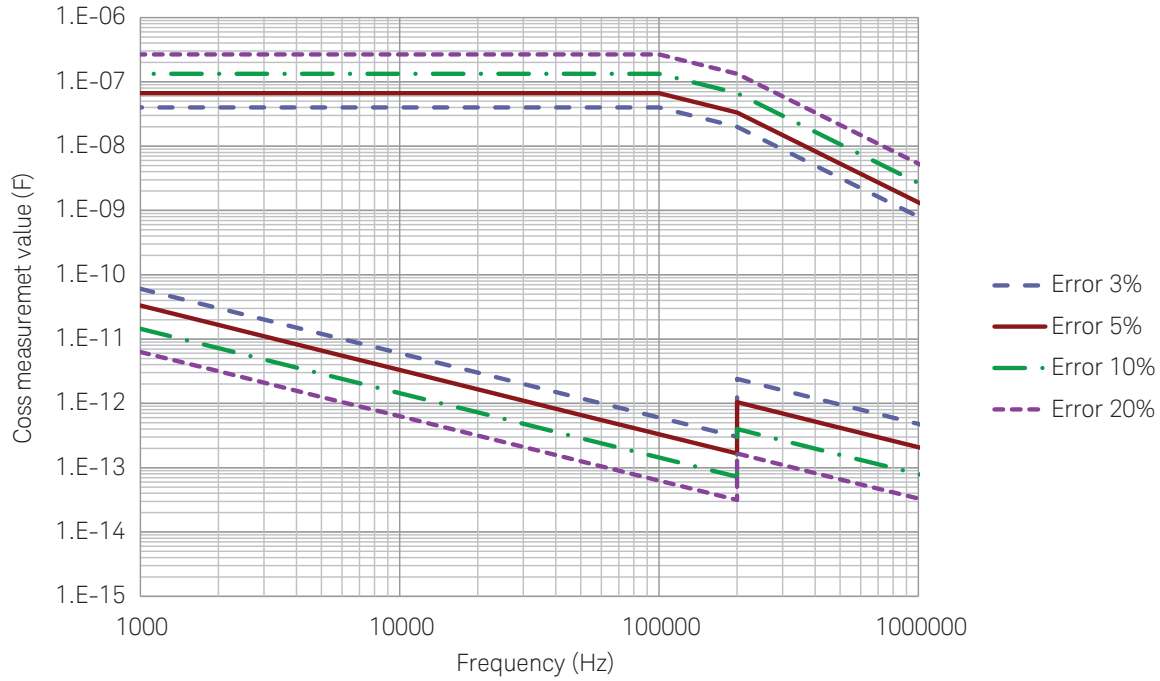

Coss measurement accuracy 3-terminal
 $C_{gs}:C_{ds}:C_{gd} = 1:0.1:0.01$

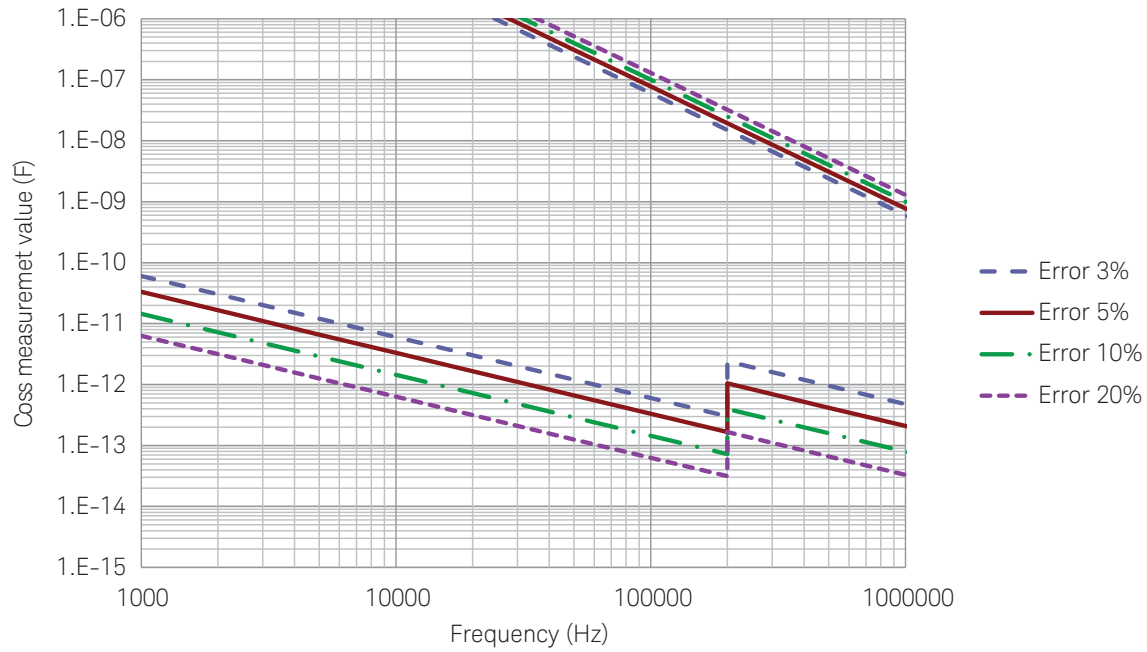

DC path leakage (Supplemental characteristics)

HVSMU port input / Drain output

Offset: 100 pA

Leakage: $V_o \times 1E-13$ (V_o : Output voltage)

HVSMU port input / Direct output

Offset: 100 pA

Leakage: $V_o \times 1E-13$ (V_o : Output voltage)

MPSMU port input / Gate output

Offset: 50 pA

Leakage: $V_o \times 5E-13$ (V_o : Output voltage)

Selector information

This information is provided for users not utilizing the N1273A capacitance test fixture but who wish to connect the selector outputs to other DUT interfaces such as a wafer prober.

Functionality

Selector capability

The selector allows the user to make connections to perform various capacitance and DC measurements such as leakage, breakdown and threshold voltage measurement.

Output terminals:

HV Triaxial: 1 ea.

SHV terminals: 4 ea.

Gate/Base

Drain/Collector

Source/Emitter

AC/DC guard

Interlock terminal: 1 ea

Digital I/O port: 1 ea. (D-sub 25 pin)

Indicators

Input terminals

HV Triaxial: 1 ea. (HVSMU)

Triaxial: 3 ea. (MPSMU Force/Sense, GNDU)

BNC: 4 ea. (MCSMU Hcur, Lcur, Hpot, Lpot)

Interlock terminal: 1 ea,

Direct IO

Output terminals for 3-terminal device

Parameter Name		Coss	Cds	Crss	Cgs	Ciss /Rg
Collector/drain	Force	Open	Open	Open	Open	Open
	Sense	High	High	High	AC Guard	Low
Emitter/source	Force	Open	Open	Open	Open	Open
	Sense	Low	Low	Low	AC Guard	Low
Base/gate	High	Low	AC Guard	Low	High	High
	Low	Open	Open	Open	Open	Open

Definition of 3-terminal device capacitances

Symbol	Description
Cgs	Capacitance between Base/Gate terminal and Emitter/Source terminal
Cds	Capacitance between Collector/Drain terminal and Emitter/Source terminal
Cgd	Capacitance between Base/Gate terminal and Collector/Drain terminal
Crss	Capacitance between Base/Gate terminal and Collector/Drain terminal
Ciss	Capacitance between Base/Gate terminal and Emitter/Source terminal and capacitance between Base/Gate terminal and Collector/Drain terminal
Coss	Capacitance between Collector/Drain terminal and Emitter/Source terminal and capacitance between Base/Gate terminal and Collector/Drain terminal

UHC (Ultra High Current) Expander / Fixture (N1265A) Specifications

Specifications

Functions:

Fixture capability

Current expander capability

Expands the B1505A's current capability up to 1500 A. Current expansion is made using the Ultra High Current Unit (UHCU), which is comprised of an external module and either two MCSMUs, two HCSMUs or one MCSMU and one HCSMU.

Selector capability

This allows the user to switch the output between the UHCU and other modules connected to the selector input ports. The modules supported on the high-voltage input port are the HVSMU and HVMCU; the modules supported on the SMU input port are the HPSMU and MPSMU.

Channels:

Channel	Number	Input	Output
SMU	6 (When using non-Kelvin connections) 3 (When using Kelvin connections)	Triaxial ¹	Banana
UHV	1	UHV coaxial (High), SHV (Low)	UHV coaxial (High), SHV (Low)
Bias Tee	1	SHV x 2(High, Low)	SHV x 2 (High, Low)
Gate control	1	Triaxial x 2 (Force, Sense)	Banana x 2 (High, Low)
Selector	1 ²	HV Triaxial x 1 Triaxial x 2 (Force, Sense)	Banana x 6 (High Force/Sense, Low Force/Sense, Guard, Chassis)

1. Either the HCSMU or the Dual HCSMU can be connected to the SMU 3 port.

2. The UHCU or any module connected to one of the other two selector input terminals can be connected to the output terminal.

Maximum output for selector channel:

HVSMU Output : ± 3000 V/4 mA, ± 1500 V/8 mA

HVMCU Output : ± 2200 V/1.1 A, ± 1500 V/2.5 A

HPSMU Output: ± 200 V/1 A

MPSMU Output: ± 100 V/100 mA

UHCU Output: ± 60 V/1500 A or 500 A

Refer to each module specification.

Gate control channel:

Non-Kelvin connection

Maximum Voltage : ± 40 V

Maximum Current : ± 1 A Pulse, 100 mA DC.

Output Resistance: 0 Ω /10 Ω /100 Ω /1000 Ω (nominal value)

UHCU:

Output peak power	
Current range	Peak power
± 500 A	7.5 kW
± 1500 A	22.5 kW

Voltage range, resolution, and accuracy				
Voltage range	Setting resolution	Measure resolution	Setting accuracy ^{1,2,3} ±(% + mV)	Measure accuracy ^{1,3} ±(% + mV)
± 60 V	200 μV	100 μV	±(0.2 + 10)	±(0.2 + 10)

- ±(% of reading value + fixed offset in mV)
- Setting accuracy is defined at open load.
- Accuracy is defined 1 ms pulse width at 500 A range and 500 μs pulse width at 1500 A range.

Current range, resolution, and accuracy ¹				
Current range	Setting resolution	Measure resolution	Setting accuracy ^{2,3} ±(% + A + A)	Measure accuracy ^{2,3} ±(% + A + A)
± 500 A	1 mA	500 μA	±(0.6 + 0.3 + 0.01*Vo)	±(0.6 + 0.3 + 0.01*Vo)
± 1500 A	4 mA	2 mA	±(0.8 + 0.9 + 0.02*Vo)	±(0.8 + 0.9 + 0.02*Vo)

- Maximum voltage compliance in current pulse mode is 63 V. Over 400 A at 500 A range and over 1200 A at 1500 A range are supplemental characteristics.
- Accuracy is defined with 1 ms pulse width at 500 A range and with 500 μs pulse width at 1500 A range.
- ±(% of reading value + fixed offset in A + proportional offset in A), Vo is the Output Voltage.

UHCU Pulse width and resolution				
Current range	Voltage pulse width	Current pulse width	Resolution	Pulse period ¹
500 A	10 μs – 1 ms	10 μs – 1 ms	2 μs	Duty ≤ 0.4%
1500 A	10 μs – 500 μs	10 μs – 500 μs	2 μs	Duty ≤ 0.1%

- At continuous maximum current output, the output current may be reduced due to insufficient charging time.

Other functionality

Filter

Filter can be used for UHC output in current mode at 500 A range.

Thermocouple input: 2 ea

Two K-type thermocouple inputs
Temperature range: -50 °C to 300 °C.

Other Terminals/Indicators

Digital I/O input: 1 ea.

Digital I/O output: 1 ea.

Power indicator: 1 ea.

High voltage indicator: 1 ea.

Selector indicator: 1 ea.

Interlock terminal: 1 ea.

Earth terminal: 1 ea.

Wrist strap terminal: 1 ea.

Supplemental characteristics

UHC Output resistance	
Output range	Nominal value
500 A	120 mΩ
1500 A	40 mΩ

Leakage

Selector channel

HVSMU is applied at High Sense terminal: less than 1 nA

HPSMU/MPSMU is applied at High Force terminal: less than 10 nA

UHVU channel

Less than 1 nA

SMU channel

Less than 1 nA

Thermocouple reading accuracy	
Temperature range	Accuracy
0 °C ≤ T < 100 °C	±2 °C
T ≥ 100 °C	±5 °C
T < 0 °C	±5 °C

UHC measurement and output range

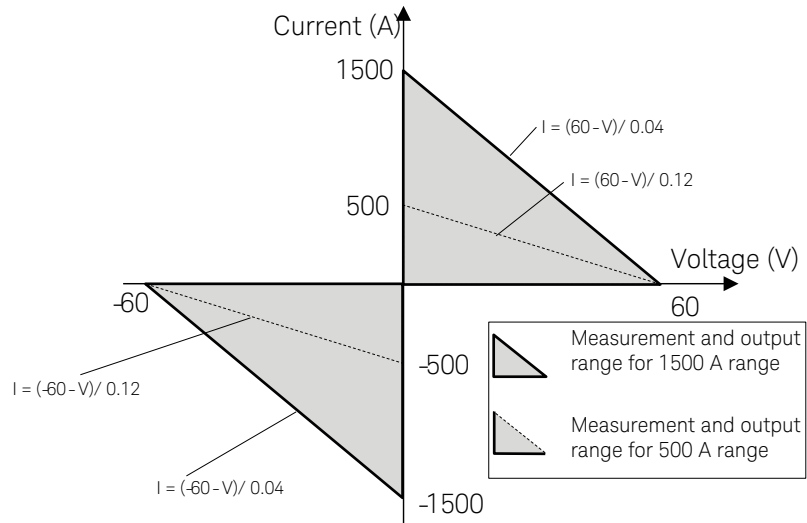

The UHCU output is only available in pulsed mode.

In the equations in the above diagram, 'I' stands for current, 'V' for Voltage.

The maximum current is defined when the output terminals are shorted.

Also, the maximum current is limited by the residual resistance of the test leads, by contact resistance between the internal jumper cable and the DUT and by the DUT impedance.

HVSMU Current Expander (N1266A) Specifications

Specifications

Functions:

Current expander capability

Expands HVSMU current up to 2.5 A. Current expansion is made using the High Voltage Medium Current Unit (HVMCU), which is comprised of a module in the N1266A, HVSMU and two MCSMUs.

Selector capability

This allows the connections between the output terminal to be switched between the HVMCU and the HVSMU. The HVSMU output can be routed either directly or through a 100 k Ω resistor.

Output Terminals:

High (HV Triaxial)

Low (BNC)

Maximum output:

HVSMU : ± 3000 V/4 mA, ± 1500 V/8 mA

HVMCU : Refer to HVMCU specification

HVMCU

Output Peak Power	
Voltage range	Peak power
± 2200 V	600 W
± 1500 V	900 W

Voltage range, resolution, and accuracy				
Voltage range	Setting resolution	Measure resolution	Setting accuracy ^{1, 2, 3} $\pm(\% + V)$	Measure accuracy ^{1, 2} $\pm(\% + V)$
± 2200 V	3 mV	3 mV	$\pm(5 + 20)$	$\pm(0.8 + 1.8)$
± 1500 V	1.5 mV	3 mV	$\pm(5 + 20)$	$\pm(0.8 + 1.8)$

1. $\pm(\%$ of reading value + fixed offset in V)
2. Accuracy is defined with 100 μ s pulse at 1.1 A range and 2.5 A range, 1 ms pulse at 100 mA range.
3. Setting accuracy is defined at open load.

Current range, resolution, and accuracy ^{1, 2}		
Current range	Measure resolution	Measure accuracy ¹ $\pm(\% + A + A)$
± 2.5 A	4 μ A	$\pm(0.9 + 4E-3 + V_0 \times 3E-7)$
± 1.1 A	4 μ A	$\pm(0.9 + 4E-3 + V_0 \times 3E-7)$
± 110 mA	200 nA	$\pm(0.9 + 2E-4 + V_0 \times 3E-7)$

1. Supplemental characteristics over 1.1 A.
2. Applicable condition: 20 averaging samples

HVMCU Pulse width and resolution		
Output range	Pulse width	Resolution
1500 V / 2.5 A	10 μ s – 100 μ s	2 μ s
2200 V / 1.1 A	10 μ s – 100 μ s	2 μ s
2200 V / 110 mA	10 μ s – 1 ms	2 μ s

Other Terminals / Indicators

Digital I/O Input: 1 ea.
 Digital I/O output: 1 ea.
 Power indicator: 1 ea
 Selector indicator: 1 ea

Supplemental characteristics

HVMCU Charged Capacitance: 0.22 μ F

Output resistance	
Output range	Nominal value
1500 V / 2.5 A	600 Ω
2200 V / 1.1 A	2000 Ω
2200 V / 110 mA	20000 Ω

HVMCU Measurement and output range

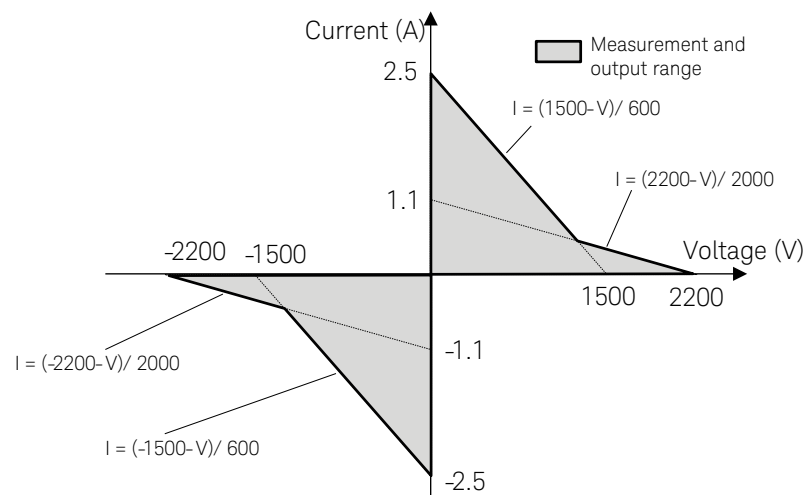

The HVMC's output is only available in pulsed mode.

In the equations in the above diagram, 'I' stands for current, 'V' for Voltage.

The maximum current is defined when the output terminals are shorted.

Also, the maximum current is limited by the residual resistance of the test leads, by contact resistance between the internal jumper cable and the DUT and by the DUT impedance.

Leakage

Selector output
 HVSMU: less than 300 pA

UHV (Ultra High Voltage) Expander (N1268A) Specifications

Specifications

Voltage range, resolution, and accuracy ¹				
Voltage range	Force resolution	Measure resolution	Setting accuracy ^{2,3} ±(% + V)	Measure accuracy ² ±(% + V)
± 10 kV	10 mV	10 mV	±(1.2 + 42)	±(1.2 + 42)

1. N1268A is controlled and makes measurement with two MCSMUs or a combination of a HCSTMU and a MCSMU.

2. ±(% of reading value + fixed offset in V)

3. Setting accuracy is defined at open load.

Current range, resolution, and accuracy ¹		
Current range	Measure resolution	Measure accuracy ² ±(% + A + A)
± 10 μA	10 pA	±(0.06 + 2E-9 + 1E-9)
± 100 μA	100 pA	±(0.06 + 2E-8 + 1E-9)
± 1 mA	1 nA	±(0.06 + 2E-7 + 1E-9)
± 10 mA	10 nA	±(0.06 + 2E-6 + 1E-9)
± 100 mA ³	100 nA	±(0.06 + 20E-6 + 1E-9)

1. N1268A is controlled and makes measurement with two MCSMUs or a combination of a HCSTMU and a MCSMU.

2. ±(% of reading value + fixed offset in A + fixed offset in A)

3. Pulsed mode only (Maximum pulse width is 1 ms). The maximum current is 20 mA.

UHV Pulse width and resolution		
Output range	Pulse width	Resolution
100 mA	100 μs to 1 ms	2 μs
≤ 10 mA	100 μs to 2 s	2 μs

Pulse Period

Min: 10 ms

Max: 5 s

Output Terminals

High : UHV coaxial

Low : SHV

Other Terminals / Indicators

Digital I/O Input: 1 ea.

Power indicator: 1 ea

High Voltage indicator: 1 ea

Interlock terminal Input: 1 ea

Interlock terminal Output: 1 ea

Earth terminal: 1 ea

Supplemental characteristics

UHVU Output resistance	
Output range	Nominal value
High	10000 Ω
Low	1000 Ω

Other AC characteristics	
Slew rate	100 V/μs (with 1 m cable)
Overshoot	±1% of setting voltage
Ripple	3 Vp-p
Maximum load capacitance	5 nF
Maximum load inductance	5 μH

UHV measurement and output range

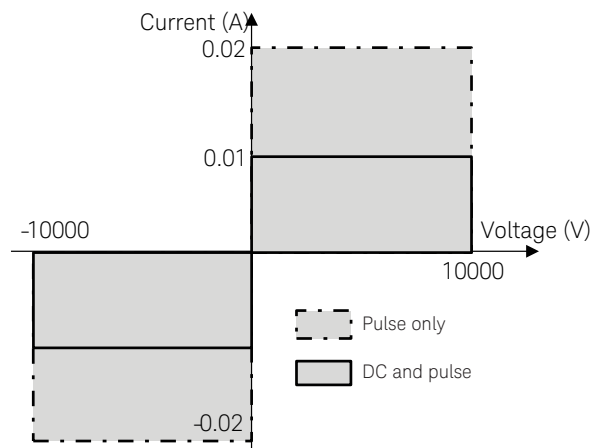

Gate charge measurement specifications

The B1505A can perform gate charge characterization for Nch MOSFETs and IGBTs. Both packaged devices and on-wafer devices are supported. The following table shows the available solutions and their required accessories (which depend on device type and current level). Temperature dependent measurements using a Thermostream or the Thermal plate are not supported.

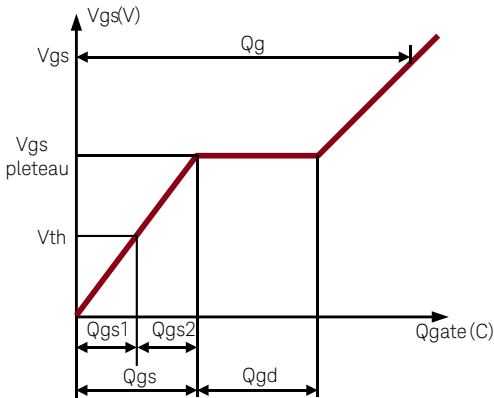

Qg: Gate charge
 Qgs: Gate-source charge
 Qgs1: Gate charge at threshold
 Qgs2: Gate charge from threshold to onset of plateau
 Qgd: Gate-drain charge

Hardware configuration and measurement/setting parameters

		Package solution			On-wafer solution		
Hardware configuration	High voltage module	B1513B/C HVSMU					
	Max voltage range	3000 V					
	High current module	B1512A HCSMU	N1265A-500	N1265A-1500A	B1512A HCSMU	N1265A-500A	N1265A-1500A
	Max current range	20 A	500 A	1500 A	20 A	500 A	1500 A
	Gate control module	B1514A MCSMU					
	Ireg control module	B1514A MCSMU					
	Fixture/selector	N1259A	N1265A		N1258A	N1265A	
	Adapter/selector	N1259AU-014	N1265AU-014		N1274A	N1275A	
Measurement parameter	Qg	1 nC to 100 μ C					
	Min resolution	10 pC					
	Vds (vce) @high voltage	0 V to +3000 V					
	Voltage/sampling resolution	3 mV / 6 μ s					
	Vds(vce) @ high current	Not Support	-60 V to 60 V		Not Support	-60 V to 60 V	
	Voltage /sampling resolution		100 μ V / 2 μ s			100 μ V / 2 μ s	
	Id (ic) maximum rated current	20 A ¹	350 A ¹	500 A ^{1,2}	20 A ¹	350 A ¹	500 A ^{1,2}
	Current/sampling resolution	2 mA / 2 μ s					
	Vgs (vge)	-30 V to +30 V					
	Voltage/sampling resolution	40 μ V / 2 μ s					
	Ig	10 nA to 1 A					
	Current/sampling resolution	10 pA / 2 μ s					

Hardware configuration and measurement/setting parameters (continued)

		Package solution			On-wafer solution		
Setting parameters	Vds (vce) @high voltage	0 V to +3000 V					
	Resolution	3 mV					
	Vds(vce) @ high current	-20 to 20 V ¹	-60 to 60 V		-40 to 40 V ¹	-60 to 60 V	
	Resolution	20 μ V	100 μ V		40 μ V	100 μ V	
	Id max	20 A ¹	450 A ¹	1100 A ^{1,2}	20 A ¹	350 A ¹	500 A ¹
	Gate drive vgs(vge)	-30 to +30 V					
	Resolution	40 μ V					
	Gate control current ig	1 μ A to 1 A					
	Resolution	0.1 μ A					
	Current regulator control voltage	-30 to +30 V					
	Resolution	40 μ V					
	On time	50 - 950 μ s	50 - 950 μ s		50 - 950 μ s	50 - 950 μ s	
	Resolution	2 μ s					

1. The maximum current will be reduced by the series resistance of the current source, residual resistance in the measurement path, and the DUT impedance.
2. The gate charge measurement adapter also has a maximum current limit of 500 A.

Target devices:

Nch MOSFETs and IGBTs in TO package, in modules and on-wafer
 Note that Pch MOSFETs are not supported.

N1267A High Voltage Source Monitor Unit / High Current Source Monitor Unit Fast Switch

Features

The N1267A supports fast switching between the HVSMU and HCSMU to enable the measurement of the Gallium Nitride current collapse effect.

The N1267A switch requires one MCSMU in the B1505A mainframe for control. The gate of the DUT (Device Under Test) can be driven by either an MCSMU or an HCSMU.

Note #1: The N1267A can only be used with the B1513B or B1503C HVSMU; it cannot be used with the B1513A HVSMU.

Note #2: The N1267A does not support the two HCSMU 40 A configuration.

Note #3: The N1267A does not support the N1265A test fixture/current expander.

Specifications

Input terminals:

HVSMU port, 1 ea (HV triaxial)

HCSMU port, 1 ea (Force: BNC, Sense: Triaxial)

MCSMU port, 1 ea (Force/Sense: Triaxial)

GND port, 1 ea (Triaxial)

Output terminals: High (HV triaxial), Low (BNC)

Maximum current: 20 A

Maximum voltage: 3000 V

Measurement mode

GaN Current collapse (Dynamic I-V) measure mode

1. I-V time domain measurement
2. I-V trace measurement

Static characteristics mode

1. Id-Vds, Vf-I_f measurement
2. Id(off)-Vds, Vr-I_r measurement

Source and Measure Range

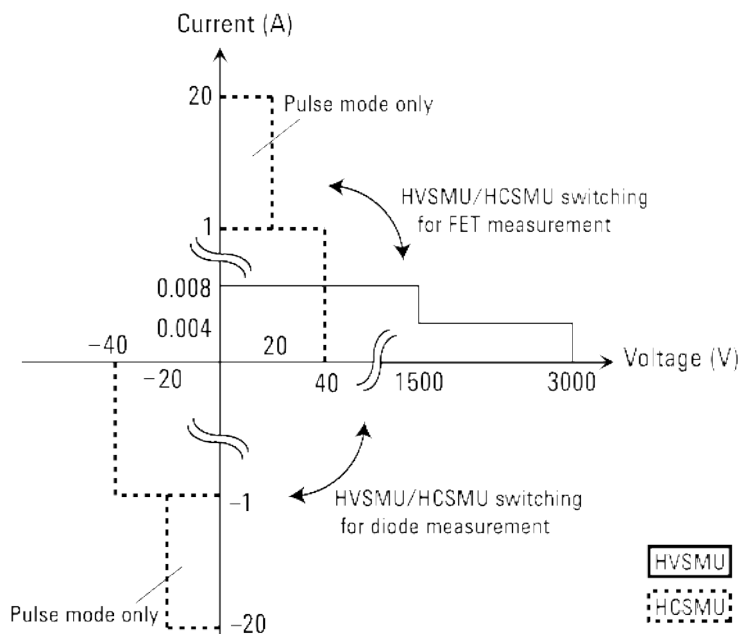

GaN current collapse measure mode

To make the GaN current collapse measurement, the HVSMU first applies high voltage stress to the DUT when the DUT is in the OFF-state. Next the HVSMU performs voltage measurement and the HCSCMU performs I-V measurement to monitor the ON-state characteristics of the DUT. When making the ON-state measurement, the HVSMU is measuring voltage and both the HVSMU and HCSCMU are used to measure the total current.

HVSMU Source setting range for OFF-state	
Voltage	Current
+1 V - +3000 V ¹	4 mA (V > 1500 V), 8 mA (V ≤ 1500 V)

¹ Setting value must be the ON state voltage plus 1 V or more.

HCSCMU source setting range for ON-state		
Voltage	Current	
0 V - ±40 V ²	Maximum	Minimum
	20 A pulse (V ≤ 20V) / 1 A DC	20 mA ³

² Voltage actually applied to the device under test (DUT) is the setting value minus the voltage drop of the switch.

³ Sum of HCSCMU output current and HVSMU output current flow into DUT.

Minimum voltage measurement resolution for OFF-state: 200 μV

Minimum current measurement resolution for ON-state: 100 nA

Minimum transition time (OFF to ON): 20 μs

Duration setting for OFF-state: 10 ms - 655.35 s

Sampling rate: 2 μs to 12 μs for current, 6 μs for voltage

Minimum ON state duration: 50 μs

Static characteristics mode

The following information applies to measurement of the DUT ON-state static characteristics. The N1267A ensures that the DUT is in the ON-state during these measurements. The HVSMU applies 0 V with 1 μA compliance and measures V_{ds} or V_f. At the same time, the HCSCMU is also performing an I-V measurement. The I_d or I_f is determined by adding together the total current measured by both the HCSCMU and the HVSMU.

HCSCMU source setting for I _d -V _{ds} , V _f -I _f measurement		
Voltage	Current	
0 V - ±40 V	Maximum	Minimum
	20 A pulse (V ≤ 20V) / 1 A DC	20 mA ⁴

Minimum voltage measurement resolution: 200 μV

Minimum current measurement resolution: 10 pA⁴)

⁴ Offset error for the I_d-V_{ds}, I_f-V_f measurement is typical 1 μA

The following information applies to measurement of the DUT OFF-state static characteristics. The N1267A ensures that the DUT is in the OFF-state during these measurements. The HCSCMU applies 0 V. At the same time, the HVSMU performs I-V measurement and measures V_{ds} or V_r. The I_d(Off) or I_r is determined by adding together the total current measured by both the HCSCMU and the HVSMU.

HVSMU source setting for I _d (off)-V _{ds} , V _r -I _r measurement		
Voltage	Current	
0 V - +3000 V	Maximum	Minimum
	4 mA (V > 1500 V), 8 mA (V ≤ 1500 V)	10 μA ⁵

Minimum voltage measurement resolution: 200 μV

Minimum current measurement resolution: 10 pA⁵)

⁵ Leak error for the I_{dss}, I_r-V_r measurement is typical 2 nA.

Accessories

N1258A module selector

Specifications

Input terminals:

- HPSMU force port¹, 1 ea., (Triaxial)
- HPSMU sense port¹, 1 ea., (Triaxial)
- HCSMU force port, 1 ea. (BNC)
- HCSMU sense port, 1 ea. (Triaxial)
- HVSMU port², 1 ea. (HV triaxial)
- GNDU port, 1 ea. (Triaxial)
- Digital I/O port, 1 ea. (D-sub 25 pin)
- AC power line connector, 1 ea.
- 1. Either HPSMU or MPSMU can be connected to HPSMU port.
- 2. Either HVSMU or HVMCU can be connected to HVSMU port.

Output terminal:

- High force (HV triaxial)
- High sense (HV triaxial)
- Low force (BNC)
- Low sense (BNC)
- External relay control output (D-sub 15 pin)

Protection:

- HPSMU, GNDU, HCSMU Low Force

Power indicator:

- LED turns yellow when AC power is applied and turns green the module selector is ready to use.

Status indicator:

- Green LED lights to indicate the present connection path of module selector;
- Open, HCSMU, HPSMU, or HVSMU.

Maximum voltage/current:

- For HPSMU port:
±200 V/1 A
- For HCSMU port:
±40 V/2 A, ±20 V/30 A
(Pulse width 1 ms, duty 1%)
- For HVSMU port:
±3000 V/4 mA,
±1500 V/2.5 A, ±2200 V/1.1 A

Supplemental characteristics

Leakage current:

- For HPSMU:
40 pA at 200 V
- For HCSMU:
100 pA at 10 V (High Force to Low Force, High Sense to Low Sense)
- For HVSMU:
300 pA at 3000 V (humidity range: 20% to 50% RH)

N1259A test fixture

Specifications

Input terminals:

- HPSMU port¹, 2 ea.
Force, sense (Triaxial)
- HCSMU port, 2 ea.
Force (BNC), sense (Triaxial)
- HVSMU port², 1 ea. (HV triaxial)
- GNDU port, 1 ea. (Triaxial)
- AUX port, 2 ea. (BNC)
- Interlock port, 1 ea.

1. Either HPSMU or MPSMU can be connected to HPSMU port.
2. Either HVSMU or HVMCU can be connected to HVSMU port.

Protection:

- HPSMU, GNDU, HCSMU Low Force terminal

High voltage indicator:

- LED turns red when a SMU output voltage is over 42 V.

Maximum voltage/current:

- For HPSMU port:
Force: ±200 V/1 A
Sense: ±200 V
- For HCSMU port:
High Force: ±40 V/2 A, ±20 V/40 A
(Pulse width 1 ms, duty 1%)
Low Force: ±40 V/2 A, ±20 V/40 A
(Pulse width 1 ms, duty 1%)
High Sense: ±40 V
Low Sense: ±40 V
- For HVSMU port:
Force: ±3000 V/4 mA,
±1500 V/2.5 A, ±2200 V/1.1 A

Note: The total power consumption of all modules cannot exceed 50 W when using test fixture under the condition that operating temperature is more than 35 °C.

Supplemental characteristics

Leakage current:

- For HPSMU (Force, Sense) port:
40 pA at 200 V (Force, Sense)
- For HCSMU (High Force, High sense) port:
100 pA at 10 V
- For HVSMU (Force) port:
300 pA at 3000 V (humidity range: 20% to 50% RH)

N1259A-010 inline package socket module (3 pin)

Specifications

Number of terminal:

- Sockets, 6 ea. (Ø4 mm jack (banana))

DUT interface:

- Inline package socket (3-pin)

Maximum voltage for terminals:

- 3000 Vdc

N1259A-011 universal socket module

Specifications

Number of terminal:

- Sockets, 8 ea. (Ø4 mm jack (banana))

Maximum voltage for terminals:

- 3000 Vdc

N1259A-013 Curve Tracer test adapter socket module

Specifications

Number of terminals:

Sockets, 6 ea.

(Ø4 mm jack (banana))

Test adapter interface:*

Sockets, 6 ea.

(Ø4 mm jack (banana))

Maximum voltage at terminals:

3000 V Vdc

Maximum current for terminals:

For Collector/Drain Force and

Emitter/Source Force

39 A (DC), 500 A (Pulse)

For others

1 A (DC), 20 A (Pulse)

*A test adapter for Tektronix curve tracers (370B/371B) can be connected to this interface.

N1259A-014 Gate Charge Socket Adapter

Purpose

To make gate charge measurements with the N1259A.

Required Hardware

- N1259A test fixture, 1 ea.
- N1259A-300 Module selector, 1 ea.
- B1512A HCSMU, 1 ea.
- B1513B/C HVSMU, 1 ea.
- B1514A MCSMU, 2 ea.

Specifications

Number of terminals: Sockets, 8 ea.

(Ø4 mm jack (banana))

Maximum voltage at terminals:

For Gate DUT High: 30 V

For Gate DUT Low: 10 V

For selector force High: 3000 V

For selector force Low: 10 V

For selector sense High: 3000 V

For selector sense Low: 10 V

For SMU control High: 30 V

For SMU control Low: 10 V

Maximum current for terminals:

For Gate DUT High: 1 A

For Gate DUT Low: 1 A

For selector force: 500 A

For selector sense: 20 mA

For SMU control: 1 A

Furnished accessories

- Test lead (red), short, 2 ea.
- Test lead (black), short, 2 ea.
- Test lead (red), long, 4 ea.
- Test lead (black), long, 4 ea.

N1259A-020 high voltage bias-tee

Specifications

Input terminals:

DC bias input, 1 ea.

(Ø4 mm jack (banana))

MFCMU port, 1 ea.

Hcur, Hpot, Lcur, Lpot, (BNC)

Guard input, 1ea (Ø4 mm banana jack)

Output terminal:

MFCMU port

High (SHV)

Low (SHV)

External DC bias voltage: ±3000 V

Frequency:

10 kHz to 1 MHz (150 Ω at 10 kHz)

Series capacitance: 110 nF ±5%

Input resistance: 100 kΩ ±1%

N1259A-021 1 MΩ resistor box

Specifications

Input/output terminals:

Ø4 mm jack (banana), 1 ea.

Resistance: 1 MΩ ±5%

Maximum voltage: ±3000 V

Power rating: 9 W

Supplemental characteristics

Leakage current: 10 pA at 100 V

N1259A-022 100 kΩ resistor box

Specifications

Input/output terminals:

Ø4 mm jack (banana), 1 ea.

Resistance: 100 kΩ ±5%

Maximum voltage: ±3000 V

Power rating: 6.4 W

Supplemental characteristics

Leakage current: 10 pA at 100 V

N1259A-030 1 kΩ resistor box for gate

Specifications

Input/output terminals:

Ø4 mm jack (banana), 1 ea.

Resistance: 1 kΩ ±10%

Maximum voltage: ±200 V

Maximum power: 1 W

Supplemental characteristics

Leakage current: 10 pA at 100 V

N1259A-035 Universal resistor box

Specifications

Input/output terminals:

Ø4 mm banana jack, 1 ea.

Resistance: Installed by a user

Maximum voltage for terminals: ±3000 V

N1259A-300 module selector for test fixture

Specifications

Input terminals:

HPSMU port¹, 1 ea.

Force, sense (Triaxial)

HCSMU port, 1 ea.

Force (BNC), sense (Triaxial)

HVSMU port², 1 ea. (HV triaxial)

GNDU port, 1 ea. (Triaxial)

Digital I/O port, 1 ea. (D-sub 25 pin)

AC power line connector, 1 ea.

1. Either HPSMU or MPSMU can be connected to HPSMU port.

2. Either HVSMU or HVMCU can be connected to HVSMU port.

Output terminal:

High force and guard
High sense and guard
Low force
Low sense
(Ø4 mm jack (banana))

Protection:

HPSMU, GNDU, HCSMU Low Force

Power indicator:

LED turns yellow when AC power is applied and turns green the module selector is ready to use.

Status indicator:

Green LED lights to indicate the present connection path of module selector; Open, HCSMU, HPSMU, or HVSMU.

Maximum voltage/current:

For HPSMU port:

±200 V/1 A

For HCSMU port:

±40 V/2 A, ±20 V/30 A

(Pulse width 1 ms, duty 1%)

For HVSMU:

±3000 V/4 mA,

±1500 V/2.5 A, ±2200 V/1.1 A

Supplemental characteristics

Leakage current:

For HPSMU:

10 pA at 200 V

For HCSMU:

100 pA at 10 V (High Force to Low Force, High Sense to Low Sense)

For HVSMU:

10 pA at 1500 V (humidity range: 20% to 70% RH)

30 pA at 3000 V (humidity range: 20% to 50% RH)

N1260A high voltage bias-tee

Specifications

Input terminals:

HVSMU port, 1 ea. (HV triaxial)

MFCMU port, 1 ea.

(4 BNC, Hp, Hc, Lp, Hc)

Output terminal:

H-AC Guard (SHV connector)

L-AC Guard (SHV connector)

External DC bias voltage: ±3000 V

Frequency:

10 kHz to 1 MHz (150 Ω at 10 kHz)

Series capacitance: 110 nF ±5%

Input resistance: 100 kΩ ±1%

N1261A protection adapter

N1261A-001 protection adapter for HPSMU (triaxial output)

Specifications

Input terminals:

Force (Triaxial)

Sense (Triaxial)

Output terminals:

Force (Triaxial)

Sense (Triaxial)

1. Either the HPSMU or the MPSMU can be connected to HPSMU port.

Supplemental characteristics

Leakage current: 10 pA at 200 V

N1261A-002 protection adapter for GNDU (BNC output)

Specifications

Input terminals:

Force/Sense (Triaxial)

Output terminals:

Force (BNC)

Sense (BNC)

N1261A-003 protection adapter for HPSMU (HV triaxial output)

Specifications

Input terminals¹:

Force (Triaxial)

Sense (Triaxial)

Output terminals:

Force (HV triaxial)

Sense (HV triaxial)

1. Either the HPSMU or the MPSMU can be connected to HPSMU port.

Supplemental characteristics

Leakage current: 10 pA at 200 V

N1261A-004 protection adapter for GNDU (SHV output)

Specifications

Input terminals:

Force/Sense (Triaxial)

Output terminals:

Force (SHV)

Sense (SHV)

N1262A Resistor Box

N1262A-001 1 MΩ resistor box

Specifications

Input terminals:

HVSMU port, 1 ea. (HV triaxial)

Output terminals:

SHV connector, 1 ea.

Resistance: 1 MΩ ±5%

Maximum voltage: ±3000 V

Maximum power: 9 W

Supplemental characteristics

Leakage current:

10 pA at 100 V

N1262A-002 100 kΩ resistor box

Specifications

Input terminals:

HVSMU port, 1 ea. (HV triaxial)

Output terminals:

SHV connector, 1 ea.

Resistance: 100 kΩ ±5%

Maximum voltage: ±3000 V

Maximum power: 6.4 W

Supplemental characteristics

Leakage current: 10 pA at 100 V

N1262A-010 1 k Ω resistor box for gate (triaxial output)

Specifications

Input terminals:
Triaxial connector, 1 ea.
Output terminals:
Triaxial connector, 1 ea.
Resistance: 1 k Ω \pm 10%
Maximum voltage: \pm 200 V
Maximum power: 1 W

Supplemental characteristics

Leakage current: 10 pA at 100 V

N1262A-011 1 k Ω resistor box for gate (SHV output)

Specifications

Input terminals:
HV triaxial connector, 1 ea.
Output terminals:
SHV connector, 1 ea.
Resistance: 1 k Ω \pm 10%
Maximum voltage: \pm 3000 V
Maximum power: 1 W

Supplemental characteristics

Leakage current: 10 pA at 100 V

N1262A-020 Universal resistor box, Triaxial

Specifications

Input terminals:
Triaxial connector, 1 ea.
Output terminals:
Triaxial connector, 1 ea.
Resistance: Installed by user
Maximum voltage for terminals: \pm 200 V

N1262A-021 Universal resistor box, HV Triaxial to SHV

Specifications

Input terminals:
HVSMU port, 1 ea. (HV triaxial)
Output terminals:
SHV connector, 1 ea.
Resistance: Installed by user
Maximum voltage for terminals: \pm 3000 V

N1262A-023 Universal resistor box for Ultra High Voltage

Specifications

Input terminals:
UHV coaxial connector, 1 ea.
Output terminals:
UHV coaxial connector, 1 ea.
Resistance: Installed by user
Maximum voltage for terminals: \pm 10 kV

N1262A-036 50 Ohm Termination Adapter

Specifications

Input terminal (BNC)
Output terminal (BNC)
Maximum power: 1 W

Accessories for N1265A

N1254A-524 Ultra High Current Prober System Cable

Specifications

Input terminals: 8 ea. (\varnothing 4 mm jack (banana))
Selector Output
High Force
High Sense
Low Force
Low Sense
Guard
Gate output
High Force
Low Force
Chassis
Output terminals
High Force (\varnothing 4 mm jack (banana))
Low Force (\varnothing 4 mm jack (banana))
High Sense (HV triaxial)
Low Sense (BNC)
Gate (BNC)
Maximum voltage / current
For High Force
 \pm 3000 V/39 A (DC), 500 A (Pulse)
For Low Force
 \pm 200 V/39 A (DC), 500 A (Pulse)
For High Sense
 \pm 3000 V/1 A
For Low Sense, Gate
 \pm 200 V/1 A

N1265A-010 Ultra High Current 3-pin Inline Package Socket Module

Specifications

Number of terminal:
Sockets, 6 ea. (\varnothing 4 mm jack (banana))
DUT interface:
Inline package socket (3-pin)
Maximum voltage for terminals:
3000 Vdc
Maximum current for terminals:
For Force
39 A (DC), 500 A (Pulse)
For sense
1A (DC), 20 A (Pulse)

N1265A-011 Universal Socket Module

Specifications

Number of terminal:
Sockets, 6 ea. (\varnothing 4 mm jack (banana))
Maximum voltage for terminals:
3000 Vdc
Universal blank area :
90 mm (W) x 81 mm (D)

N1265A-013 Curve Tracer Test Adapter Socket Module

Specifications

Number of terminals: Sockets, 6 ea. (\varnothing 4 mm jack (banana))
Test adapter interface:*
Sockets, 6 ea. (\varnothing 4 mm jack (banana))
Maximum voltage at terminals:
3000V Vdc
Maximum current for terminals:
For Collector/Drain Force and Emitter/Source Force
39 A (DC), 500 A (Pulse)
For others
1 A (DC), 20 A (Pulse)

*A test adapter for Tektronix curve tracers (370B/371B) can be connected to this interface.

N1265A-014 Gate Charge Socket Adapter

Purpose

To make gate charge measurements with the N1265A.

Required Hardware

- N1265A UHC expander, 1 ea.
- B1513B/C HVSMU, 1 ea.
- B1514A MCSMU, 2 ea.

Specifications

Number of terminals: Sockets, 8 ea.
(Ø4 mm jack (banana))

Maximum voltage at terminals:

- For Gate DUT High: 30 V
- For Gate DUT Low: 10 V
- For selector force High: 3000 V
- For selector force Low: 10 V
- For selector sense High: 3000 V
- For selector sense Low: 10 V
- For SMU control High: 30 V
- For SMU control Low: 10 V

Maximum current for terminals:

- For Gate DUT High: 1 A
- For Gate DUT Low: 1 A
- For selector force: 500 A
- For selector sense: 20 mA
- For SMU control: 1 A

Furnished accessories

- Ultra high current banana test lead, 2 ea.
- Test lead (red), short, 2 ea.
- Test lead (black), short, 2 ea.
- Test lead (red), long, 2 ea.
- Test lead (black), long, 2 ea.

N1265A-035 Universal R-Box for N1265A

Specifications

Input: 4 ea. (Ø4 mm plug (banana))
High (Force, Sense)
Low (Force, Sense)

Output terminals: 2 ea. (Ø4 mm jack (banana))
High, Low

Resistance: Installed by a user

Maximum voltage for terminals: ±200 V

N1265A-040 10 kV Ultra High Voltage Gate Protection Adapter

Specifications

Input: 4 ea. (Ø4 mm plug (banana))
High (Force, Sense)
Low (Force, Sense)

Output terminals: 2 ea. (Ø4 mm jack (banana))
High, Low

Maximum voltage: ±200 V

Maximum surge voltage: ±10 kV

N1265A-041 Thermocouple, Type K, 2 ea

Feature

N1265A-041 can be connected to Thermocouple terminal inside the N1265A and enables B1505A to read out temperature at the top of the thermocouple.

Specifications

Connector: Type K plug
Length: 3000 mm

N1265A-045 Container for Protection Adapter and Bias Tee

Feature

N1265A-045 can accommodate protection adapters and bias tee which are used with N1265A to make the measurement environment clean and safe

Specifications

Dimension: 420 mm W x 193 mm
H x 565 mm D
Weight: 15 kg
Maximum superimposed load: 50 kg

N1269A Ultra High Voltage Connection Adapter

Feature

To make the connection simple and to protect measurement resources from

unexpected surge when connecting UHVU to wafer prober.

Specifications

Input terminals:

Gate MCSMU Force, 1 ea (Triaxial)
Gate MCSMU Sense, 1 ea (Triaxial)
Chuck MCSMU Force, 1 ea (Triaxial)
Chuck MCSMU Sense, 1 ea (Triaxial)

UHV Low, 1ea (HV triaxial)

Output terminals: 3ea (SHV)

Gate, Chuck, Source

Maximum voltage: ±200 V

Maximum surge voltage: ±10 kV

N1271A Thermal test enclosure

Operation Condition

Temperature: +5 °C to 30 °C

Humidity: 20% to 70% RH, Non-condensing

Accuracy specifications degrade by a factor of 3x versus measurements made without the thermal enclosure.

(Supplemental characteristics)

Common furnished accessories:

- 200 mm high current cable, 2 ea.
- 300 mm high current cable, 2 ea.
- 200 mm normal cable, 6 ea.
- 300 mm normal cable, 4 ea.
- Banana pin adapter, 14 ea.
- Mini alligator clip, 10 ea.
- Large clip, 4 ea.

N1271A-001 Thermal plate compatible enclosure for N1259A/N1265A

Purpose

Supports placement of the inTEST Thermal Plate within the test fixtures (N1259A/N1265A) to enable temperature dependency measurements up to 250 °C.

The inTest thermal plate with GP-IB control option is necessary for automated thermal measurement.

N1271A-002 Thermostream compatible enclosure for N1265A (3 kV IV)

Purpose

To enable thermal testing by creating an interface between the N1265A and an inTEST Thermostream. The enclosure supports fully automated IV temperature measurements from -50 °C. to +220 °C.

Specifications

Accuracy specifications degrade by a factor of 3x versus measurements made without the thermal enclosure. (Supplemental characteristics)

Number of channels

SMU: 6 (When using non-Kelvin connections), 3 (When using Kelvin connections)

Gate: 1

Selector output: 1

N1271A-005 Thermostream compatible enclosure for N1265A (3 kV IV, CV & 10kV)

Purpose

To enable thermal testing by creating an interface between the N1265A and an inTEST Thermostream. The enclosure supports fully automated IV and CV measurements up to 3 kV, and IV measurements up to 10 kV at temperature ranging from -50 °C. to +220 °C.

Specifications

Accuracy specifications degrade by a factor of 3x versus measurements made without the thermal enclosure. (Supplemental characteristics)

Number of channels

SMU: 4 (When using non-Kelvin connections), 2 (When using Kelvin connections)

Gate: 1

Gate with protection resistor for UHV: 1

Selector output: 1

UHV: 1

Capacitance: 1

N1273A Capacitance Test Fixture

Purpose

To enable packaged device capacitance testing in conjunction with the N1272A Device Capacitance Selector.

Specifications

Input terminals:

Collector/Drain (SHV) 3000 V 20 mA

Base/Gate (SHV) 100 V 100 mA

Emitter/Source (SHV) 100 V 120 mA

AC/DC Guard (SHV) 3000 V 100 mA

Interlock port, 1 ea.

Earth terminal

High voltage indicator:

LED turns red when a SMU output is over 42V.

Maximum voltage for SHV port: 3 kV

Furnished accessories

- System cable between selector and test fixture (SHV x 4, Interlock, Earth), 1 ea.
- 3-pin Inline Package Socket Module, 1 ea
- 200 mm normal cable, 4 ea.
- Banana pin adapter, 4 ea.
- Mini alligator clip, 4 ea.
- M5 8 mm Torx pan head screw, 2 ea.

N1273A-011 Universal Socket Module

Specifications

Number of terminals: Sockets, 6 ea. (04 mm jack (banana))

Maximum voltage for terminals: 3 kV

Furnished accessories:

Test wire for thermal test (2 m)

Lag connectors x 14

Screws

N1273A-013 Curve Tracer Test Adapter Socket Module

Specifications

Number of terminals: Sockets, 6 ea. (04 mm jack (banana))

(Sense terminals of this adapter are open.

Only force terminals are connected to output terminals of N1273A.)

Maximum voltage for terminals: 3 kV 100 mA

*A test adapter for Tektronix curve tracers (370B/371B) can be connected to this interface.

N1274A On-Wafer Gate Charge measurement adapter/selector for 20 A/3 kV

Purpose

To enable gate charge measurements on-wafer using the HCSMU (20 A) and HVSMU (3 kV).

Note: The connection changes to switch between IV measurement and gate charge measurement are automatically performed via high voltage/high current switches in the N1258A module selector and relays in the N1274A.

Required Hardware

The following modules and accessories are required in addition to the N1274A.

N1258A Module selector

B1512A HCSMU

B1513B/B1513C HVSMU

B1514A MCSMU x 2

Current control MOSFET/IGBT

Specifications

Input terminals (Connector) [Maximum voltage/current]:

- Current control MCSMU Force (Triaxial) [±30 V/1 A]
- Current control MCSMU Sense (Triaxial) [±30 V/1 A]
- DUT Gate control MCSMU/HCSMU Force (Triaxial) [±30 V/1 A]
- DUT Gate control MCSMU/HCSMU Sense (Triaxial) [±30 V/1 A]

- High Force (HV triaxial) [± 3 kV/20 A]
- High Sense (HV triaxial) [± 3 kV/20 A]
- Low Force (BNC) [± 40 V/20 A]
- Low Sense (BNC) [± 40 V/1 A]
- Relay control port (D-sub 15 pin)

Output terminal (Connector) [Maximum voltage/current]:

- High Force (banana) [± 30 V/1 A]
- High Sense (HV triaxial) [± 30 V/1 A]
- Low Force (banana) [± 30 V/1 A]
- Low Sense (banana) [± 30 V/1 A]
- Gate (BNC) [± 40 V/20 A]

Supplemental characteristics

DC leakage:

- 1 nA at 3000 V (for HVSMU)
- 1 nA at 100 V (for MPSMU)
- 1 nA at 200 V (for HPSMU)
- 1 nA at 40 V (for HCSMU)

Furnished cables

- HCSMU cable 30 cm, 2 ea.
- HVSMU cable 35 cm, 1 ea.
- HVTriaxial plug coax cable 35 cm, 1 ea.
- Relay control cable 30 cm, 1 ea.

N1275A On-Wafer Gate Charge measurement adapter for N1265A

Purpose

To enable on-wafer gate charge measurements with the UHCU (500 A) and HVSMU (3 kV)

Note: Unlike the N1274A, switching between IV and Qg requires manual connection changes.

Required Hardware

The following modules and accessories are required in addition to the N1274A.

- N1265A Ultra High Current Expander
- N1254A-524 Prober System Cable
- B1513B/B1513C HVSMU
- B1514A MCSMU x 2
- Current control MOSFET/IGBT

Specifications

Input terminals (Connector) [Maximum voltage/current]:

- Current control MCSMU Force (Triaxial) [± 30 V/1 A]
- Current control MCSMU Sense (Triaxial) [± 30 V/1 A]
- High Force from N1254A Opt524 (banana) [± 60 V/500 A]
- Low Sense from N1254A Opt524 (BNC) [± 10 V/1 A]
- Output terminal (Connector) [Maximum voltage/current]:
- High Force to DUT (banana) [± 60 V/500 A]
- Low Sense to DUT (banana) [± 10 V/1 A]
- Gate (BNC) [± 40 V/20 A]

Furnished cables

- Ultra high current banana to banana cable (30 cm), 1 ea.
- BNC cable (30 cm), 1 ea.

Keysight EasyEXPERT group+ Software

Keysight EasyEXPERT group+ GUI based characterization software is available either on the B1505A's embedded Windows 10 platform with 15-inch touch screen or on your PC to accelerate the characterization tasks. It supports efficient and repeatable device characterization in the entire characterization process from measurement setup and execution to analysis and data management either interactive manual operation or automation across a wafer in conjunction with a semiautomatic wafer prober. EasyEXPERT group+ makes it easy to perform complex device characterization immediately with the hundreds of

ready-to-use measurements (application tests) furnished, and allows you the option of storing test condition and measurement data automatically after each measurement in a unique built-in database (workspace), ensuring that valuable information is not lost and that measurements can be repeated at a later date. Finally, EasyEXPERT has built-in analysis capabilities and a graphical programming environment that facilitate the development of complex testing algorithms.

Key features

- Multiple measurement modes for quick setup and measurement execution (application test, classic test, tracer test, quick test and oscilloscope view)
- Graphical display, automated analysis capabilities and data generation to Excel and image for analysis and reporting
- Built-in database (workspace) records test data automatically and simplifies the data management without numerous data files
- GUI-based self-test, self-calibration and diagnostics menu for hardware maintenance
- EasyEXPERT group+ remote control function supports the remote measurement execution of application tests that are created on GUI interactively, via the LAN interface
- Data back capability and various data protection feature for shared usage by multiple users
- Characterization environment is available either on mainframe (embedded Windows 10) or on user's PC as a personal and portable analyzer environment. EasyEXPERT group+ can be installed on any PC as many as needed without additional charge.

Device Type	Application Tests
Power MOSFET (Si, GaN)	Id-Vds, Rds-Id, Id-Vgs, Vth, Cgs, Cds, Cgd, Current collapse, Breakdown, QSCV, etc.
IGBT	Ic-Vce, Ic-Vge, Vth, Cge, Cce, Cgc, Breakdown, etc.
SiC, Ga ₂ O ₃	Id-Vds, Rds-Id, Id-Vgs, Vth, Cgs, Cds, Cgd, Breakdown, QSCV, etc.
Power BJT	Ic-Vce, Vce(sat), Ic-Vcbo, Ic-Vceo, Ie-Vbeo, etc.
Power Diode	If-Vf, Ir-Vr, Cj-Vr, etc.
Capacitor	C-V, C-f, C-t, leak-V, Breakdown, TDDb, etc.
And more	And more

Application library

EasyEXPERT group+ comes with over 40 application tests conveniently organized by device type, application, and technology. You can easily edit and customize the furnished application tests to fit your specific needs. Application tests are provided for the following categories; they are subject to change without notice.

Measurement modes and functions

Operation mode:

Application test mode

The application test mode provides application oriented point-and-click test setup and execution. An application test can be selected from the library by device type and desired measurement, and then executed after modifying the default input parameters as needed.

Classic test mode

The classic test mode provides function oriented test setup and execution with the same look, feel, and terminology of the 4155/4156 user interface. In addition, it improves the 4155/4156 user interface by taking full advantage of EasyEXPERT group+'s GUI features.

Tracer test mode

The tracer test mode offers intuitive and interactive sweep control using a rotary knob similar to a curve tracer. Just like an analog curve tracer, you can sweep in only one direction (useful for R&D device analysis) or in both directions (useful in failure analysis applications). Test set ups created in tracer test mode can be seamlessly and instantaneously transferred to classic test mode for further detailed measurement and analysis.

Each SMU can sweep using VAR1 (primary sweep), VAR2 (secondary sweep), or VAR1' (synchronous sweep).

Oscilloscope view

The oscilloscope view (available in tracer test mode) displays measured current or voltage data versus time. The pulsed measurement waveforms appear in a separate window for easy verification of the measurement timings. This function is useful for verifying waveform timings and debugging pulsed measurements. The following modules are supported in this view: HCSMU, MCSMU, HVSMU, UHCU, HVMCU, and UHVU. The oscilloscope view can display the pulsed waveform timings at any (user specified) sweep step of the sweep output.

Sampling interval:

- 2 μ s (HCSMU/MCSMU/UHCU/HVMCU/UHVU)
- 6 μ s (HVSMU)

Sampling points:

- 2000 Sa (HCSMU/MCSMU/UHCU/HVMCU/UHVU)
- 4000 Sa (HVSMU)

Marker function:

- Read-out for each data channel
- Resolution: 2 μ s

Data saving:

- Numeric: Text/CSV/XMLSS
- Image: EMF/BMP/JPG/PNG

Quick test mode

A GUI-based Quick Test mode enables you to perform test sequencing without programming. You can select, copy, rearrange and cut-and-paste any application tests with a few simple mouse clicks. Once you have selected and arranged your tests, simply click on the measurement button to begin running an automated test sequence.

Measurement modes:

The Keysight B1505A supports the following measurement modes:

- IV measurement
 - Spot
 - Staircase sweep
 - Pulsed spot
 - Pulsed sweep
 - Staircase sweep with pulsed bias
 - Sampling
 - Multi-channel sweep
 - Multi-channel pulsed sweep
 - List sweep
 - Linear search¹
 - Binary search¹
- C measurement
 - Spot C
 - CV (DC bias) sweep
 - Pulsed spot C
 - Pulsed sweep CV
 - C-t sampling
 - C-f sweep
 - CV (AC level) sweep
 - Quasi-Static CV (QSCV)

1. Supported only by FLEX commands.

Sweep measurement

- Number of steps: 1 to 10001 (SMU), 1 to 1001 (CMU)
- Sweep mode: Linear or logarithmic (log)
- Sweep direction: Single or double sweep
- Hold time: 0 to 655.35 s, 10 ms resolution

Recommended GPIB I/F

		Interface	B1505A
Keysight	82350B/C	PCI	✓ ¹
	82357A	USB	✓ ²
	82357B	USB	✓ ²
National Instrument	GPIB-USB-HS	USB	✓ ²

1. An 82350B/C card is highly recommended because of stability and speed.

2. USB GPIB interfaces might cause serial poll error intermittently due to the intrinsic communication scheme differences. It is reported that using an even GPIB address sometimes significantly decreases the chance of the error. The NI GPIB-USB-HS is recommended for stability, and the Keysight 82357B is recommended for speed.

Delay time:

0 to 65.535 s, 100 μ s resolution
0 to 655.35 s, 100 μ s resolution
(CV (AC level) sweep, C-f sweep)

Step delay time:

0 to 1 s, 100 μ s resolution

Step output trigger delay time:

0 to (delay time) s, 100 μ s resolution

Step measurement trigger delay time:

0 to 65.535 s, 100 μ s resolution

Sampling (time domain) measurement

Displays the time sampled voltage/current data (by SMU) versus time.

Sampling channels: Up to 10

Sampling mode: Linear, logarithmic (log)

Sampling points:

For linear sampling:

1 to 100,001/(number of channels)

For log sampling:

1 to 1+ (number of data for 11 decades)

Sampling interval range:

100 μ s to 2 ms, 10 μ s resolution

2 ms to 65.535 s, 1 ms resolution

For < 2 ms, the interval is $\geq 100 \mu$ s
+20 μ s x (num. of channels - 1)

Hold time, initial wait time:

-90 ms to -100 μ s, 100 μ s resolution

0 to 655.35 s, 10 ms resolution

Measurement time resolution: 100 μ s

Other measurement characteristics

Measurement control

Single, repeat, append, and stop

SMU setting capabilities

Limited auto ranging, voltage/current compliance, power compliance, automatic sweep abort functions, self-test, and self-calibration

Standby mode

SMUs in "Standby" remain programmed to their specified output value even as other units are reset for the next measurement.

Bias hold function

This function allows you to keep a source active between measurements. The source module will apply the specified bias between measurements when running classic tests inside an application test, in quick test mode, or during a repeated measurement. The function ceases as soon as these conditions end or when a measurement that does not use this function is started.

Current offset cancel

This function subtracts the offset current from the current measurement raw data, and returns the result as the measurement data. This function is used to compensate the error factor (offset current) caused by the measurement path such as the measurement cables, manipulators, or probe card.

Time stamp

The B1505A supports a time stamp function utilizing an internal quartz clock.

Resolution: 100 μ s

Data display, analysis and arithmetic functions

Data Display

X-Y graph plot

X-axis and up to eight Y-axes, linear and log scale, real time graph plotting. X-Y graph plot can be printed or stored as image data to clip board or mass storage device. (File type: bmp, gif, png, emf)

Scale:

Auto scale and zoom

Marker:

Marker to min/max, interpolation, direct marker, and marker skip

Cursor:

Direct cursor

Line:

Two lines, normal mode, grad mode, tangent mode, and regression mode.

Overlay graph comparison:

Graphical plots can be overlaid.

List display

Measurement data and calculated user function data are listed in conjunction with sweep step number or time domain sampling step number. Up to 20 data sets can be displayed.

Data variable display

Up to 20 user-defined parameters can be displayed on the graphics screen.

Automatic analysis function

On a graphics plot, the markers and lines can be automatically located using the auto analysis setup. Parameters can be automatically determined using automatic analysis, user function, and read out functions.

Analysis functions

Up to 20 user-defined analysis functions can be defined using arithmetic expressions. Measured data, pre-defined variables, and read out functions can be used in the computation. The results can be displayed on the LCD.

Read out functions

The read out functions are built-in functions for reading various values related to the marker, cursor, or line.

Arithmetic functions

User functions

Up to 20 user-defined functions can be defined using arithmetic expressions. Measured data and pre-defined variables can be used in the computation. The results can be displayed on the LCD.

Arithmetic operators

+, -, *, /, ^, abs (absolute value), at (arc tangent), avg (averaging), cond (conditional evaluation), delta, diff (differential), exp (exponent), integ (integration), lgt (logarithm, base 10), log (logarithm, base e), mavg (moving average), max, min, sqrt, trigonometric function, inverse trigonometric function, and so on.

1. In case of some supplemental characteristics, humidity range is defined as 20% to 50% RH

Physical constants

Keyboard constants are stored in memory as follows:

q: Electron charge, 1.602177E-19 C

k: Boltzmann's constant, 1.380658E-23

ϵ (e): Dielectric constant of vacuum, 8.854188E-12

Engineering units

The following unit symbols are also available on the keyboard:

a (10^{-18}), f (10^{-15}), p (10^{-12}), n (10^{-9}),

u or μ (10^{-6}), m (10^{-3}), k (10^3),

M (10^6), G (10^9), T (10^{12}), P (10^{15})

Data management

Workspace (Built-in database)

EasyEXPERT group+ supports the built-in database called "workspace". Workspaces are created on a SSD, and they enable to manage and access all the measurement related data without handling numerous files. Every workspace supports the following features:

- Access to measurement capabilities and data stored in the workspace.
- Save/Import/Export measurement settings and data (application library, measurement settings, my favorite setup, and measurement data)
- Recall the setup for measurement reproduction and data for analysis

Data auto record/ auto export

EasyEXPERT group+ has the ability to automatically store the measurement setup and data within a workspace. It can also export measurement data in real time, in a variety of formats such as Excel (xls).

Import/export files

File type:

Keysight EasyEXPERT format, XML-SS format, CSV format

Data Protection

EasyEXPERT group+ has various options to protect important data as follows.

- Password protection (workspace, test definition and my favorite)
- User level access control (engineer mode/operator mode)

Workspace back-up and portability

EasyEXPERT group+ has the ability to import/export a workspace for back-up and portability.

General specification

Temperature range

Operating: +5 °C to +40 °C

Storage: -20 °C to +60 °C

Humidity range¹

Operating: 20% to 70% RH, non-condensing

Storage: 10% to 90% RH, non-condensing

Storage: 20% to 80% RH, non-condensing (N1268A)

Altitude

Operating: 0 m to 2,000 m (6,561 ft)

Storage: 0 m to 4,600 m (15,092 ft)

0 m to 2,000 m (6,561 ft) (N1268A)

Power requirement

ac Voltage: 90 V to 264 V

Line Frequency: 47 Hz to 63 Hz

Maximum volt-amps (VA)

B1505A: 900 VA

N1258A: 65 VA

N1259A-300: 35 VA

N1265A: 400 VA

N1266A: 60 VA

N1268A: 350 VA

N1272A: 70 VA

Acoustic Noise Emission

Lpa < 65 dB

Lwa: 66 dB (Operating mode)

Lwa: 73 dB (Worst case mode)

About measurement accuracy

RF electromagnetic field and SMU measurement accuracy: SMU voltage and current measurement accuracy can be affected by RF electromagnetic field strengths greater than 3 V/m in the frequency range of 80 MHz to 1 GHz. The extent of this effect depends upon how the instrument is positioned and shielded.

Induced RF field noise and SMU measurement accuracy:

SMU voltage and current measurement accuracy can be affected by induced RF field noise strengths greater than 3 Vrms in the frequency range of 150 kHz to 80 MHz. The extent of this effect depends upon how the instrument is positioned and shielded.

Regulatory compliance

EMC:

IEC 61326-1 / EN 61326-1

Canada: ICES/NMB-001

AS/NZS CISPR 11

Safety:

IEC61010-1 / EN 61010-1

CAN/CSA-C22.2 No. 61010-1

Certification

CE, cCSAus, RCM

Dimensions

B1505A:

420 mm W x 330 mm H x 575 mm D

N1258A module selector:

330 mm W x 120 mm H x 410 mm D

N1259A test fixture:

420 mm W x 272 mm H x 410 mm D

N1260A High voltage bias-tee:

164 mm W x 53 mm H x 125 mm D

N1261A-001 HPSMU protection adapter (Triaxial output):

80 mm W x 40 mm H x 110 mm D

N1261A-002 GNDU protection adapter (BNC output):

80 mm W x 40 mm H x 110 mm D

N1261A-003 HPSMU protection adapter (HV triaxial output):

90 mm W x 40 mm H x 140 mm D

N1261A-004 GNDU protection adapter (SHV output):

80 mm W x 40 mm H x 125 mm D

N1262A resistor box:
 50 mm W x 40 mm H x 125 mm D
 N1265A UHC expander / fixture:
 420 mm W x 285mm H x 575 mm D
 N1266A HVSMU current expander:
 420 mm W x 75 mm H x 575 mm D
 N1267A HVSMU / HCSPMU fast
 switch:
 202 mm W x 56 mm H x 175 mm D
 N1268A UHV expander:
 420 mm W x 222 mm H x 482 mm D
 N1269A Ultra High Voltage
 Connection Adapter:
 134 mm W x 56 mm H x 150 mm D
 N1271A-001 Thermal plate compatible
 enclosure for N1259A/N1265A
 500 mm W 190 mm H 365 mm D
 N1271A-002 Thermostream compatible
 enclosure for N1265A (3kV IV)
 330 mm W 340 mm H 430 mm D (Outer
 dimension)
 284 mm W 150 mm H 195 mm D (Inner
 dimension)
 N1271A-005 Thermostream compatible
 enclosure for N1265A (3kV IV, CV & 10kV)
 330 mm W 340 mm H 430 mm D (Outer
 dimension)
 275 mm W 150 mm H 195 mm D (Inner
 dimension)
 N1272A:
 420 mm W x 75 mm H x 575 mm D
 N1273A:
 340 mm W x 200 mm H x 345 mm D
 N1274A:
 330 mm W x 90 mm H x 410 mm D
 N1275A:
 116 mm W x 78 mm H x 125 mm D

N1268A: 18 kg
 N1269A: 0.4 kg
 N1271A-001: 4.5 kg
 N1271A-002: 10.5 kg
 N1271A-005: 10.5 kg
 N1272A: 9.4 kg
 N1273A: 0.7 kg
 N1274A: 3.2 kg
 N1275A: 0.4 kg

Furnished accessories

Measurement cables and adapter
 Triaxial cable for HPSMU, MPSMU and
 MCSMU, 2 ea.
 HCSPMU cable, 1 ea.
 HCSPMU Kelvin adapter, 1 ea.
 HVSMU cable, 1 ea.
 Interlock cable, 1 ea.
 Ground unit cable, 1 ea.
 Keyboard, 1 ea.
 Mouse, 1 ea.
 Stylus pen, 1 ea.
 Power cable, 1 ea.
 Product CD-ROM, 1 ea.
 Software entitlement document for
 EasyEXPERT group+
 SMU number label for the B1505A installed
 with SMU, 1 sheet
 N1258A : Digital I/O cable, 1 ea.
 N1259A-300 : Digital I/O cable, 1 ea.
 N1265A : Digital I/O cable, 1 ea.
 N1266A : Digital I/O cable, 1 ea.
 N1268A : Digital I/O cable, 1 ea.,
 Interlock cable, 1 ea.
 N1272A : Digital I/O cable 1.5m, 1 ea
 HVSMU cable 1.5 m, 1 ea.

Weight

B1505A (empty): 20 kg
 B1511B: 1.1 kg
 B1510A: 2.0 kg
 B1512A: 2.1 kg
 B1513C: 2.0 kg
 B1514A: 1.3 kg
 B1520A: 1.3 kg
 N1258A: 5.0 kg
 N1259A: 12.0 kg
 N1260A: 0.6 kg
 N1261A: 0.3 kg
 N1262A: 0.3 kg
 N1265A: 30 kg
 N1266A: 10 kg
 N1267A: 0.8 kg

Order Information

Mainframe and modules	
B1505A	Power Device Analyzer/Curve Tracer mainframe Configure the following modules: High power SMU (HPSMU) Medium power SMU (MPSMU) High current SMU (HCSMU) Medium current SMU (MCSMU) High voltage SMU (HVSMU) Multi frequency CMU (MFCMU)
B1505A-015	1.5 m cable
B1505A-030	3.0 m cable
B1505A-050	50 Hz line frequency
B1505A-060	60 Hz line frequency
B1505A-A6J	ANSI Z540 compliant calibration
B1505A-UK6	Commercial calibration certificate with test data
B1505A-ABA	English documentation
B1505A-ABJ	Japanese documentation
B1500A-1CM	Rackmount kit
B1505A expanders/fixtures	
N1259A	Test fixture
N1259A-010	Inline package socket module (3 pin)
N1259A-011	Universal socket module
N1259A-012	Blank PTFE board
N1259A-013	Curve Tracer test adaptor socket module
N1259A-014	Gate Charge socket adapter
N1259A-020	High voltage bias-tee
N1259A-021	1 M Ω Resistor box
N1259A-022	100 k Ω Resistor box
N1259A-030	1 k Ω Resistor box for gate
N1259A-035	Universal R-Box
N1259A-300	Module selector
N1265A	UHC expander / fixture
N1265A-010	500 A Ultra High Current 3-pin Inline Package Socket Module
N1265A-011	Universal Socket Module
N1265A-013	Curve Tracer Test Adapter Socket Module
N1265A-014	Gate Charge socket adapter
N1265A-015	1500 A Current Option
N1265A-035	Universal R-Box for N1265A
N1265A-040	10 kV Ultra High Voltage Gate Protection Adapter
N1265A-041	Thermocouple, Type K, 2 ea
N1265A-045	Container for Protection Adapter and Bias Tee
N1266A	High Voltage Source Monitor Unit Current Expander
N1267A	High Voltage Source Monitor Unit / High Current Source Monitor Unit Fast Switch
N1268A	Ultra High Voltage Expander
N1271A	Thermal Test Enclosure
N1271A-001	Thermal plate compatible enclosure for N1259A/N1265A
N1271A-002	Thermostream compatible enclosure for N1265A (3kV IV)
N1271A-005	Thermostream compatible enclosure for N1265A (3kV IV, CV & 10kV)
N1272A	Device Capacitance Selector
N1273A	Capacitance Test Fixture
N1273A-011	Universal Socket Module
N1273A-013	Curve Tracer Test Adapter Socket Module
N1274A	On-Wafer Gate Charge measurement adapter/selector for 20 A/3 kV
N1275A	On-Wafer Gate Charge measurement adapter for N1265A
B1505A accessories	
16444A-001	Keyboard
16444A-002	Mouse
16444A-003	Stylus pen
N1253A-100	Digital I/O cable
N1253A-200	Digital I/O BNC box
N1254A-100	Ground unit Kelvin adapter
N1254A-101	Triaxial(m)-BNC(f)
N1254A-102	Triaxial(m)-BNC(m)
N1254A-103	Triaxial(m)-BNC(f)
N1254A-104	Triaxial(f)-BNC(m)
N1254A-105	Triaxial(f)-BNC(m)
N1254A-106	Triaxial(m)-BNC(f)
N1254A-107	Triaxial(m)-BNC(f)
N1254A-500	HV Jack Connector (Solder Type)
N1254A-501	HV Jack /Jack Adapter
N1254A-502	HV plug Connector(Solder Type)
N1254A-503	BNC Coax Cable Assy 1.5m(Open End)
N1254A-504	HVTriax Jack Coax Cable Assy 1.5m(Open End)
N1254A-505	HVTriax Plug Triax Cable Assy 1.5m (Open End)
N1254A-506	HVTriax Plug Coax Cable Assy 1.5m(Open End)
N1254A-507	HVTriax Plug Coax Cable Assy 1.5m
N1254A-508	Test Lead cable Black
N1254A-509	Test Lead cable Red
N1254A-510	Dolphin clip 2 ea. (red and black)
N1254A-511	Cable lag adapter 2 ea. (red and black)
N1254A-512	SHV Cable Assy 250 mm
N1254A-513	SHV to Banana
N1254A-514	BNC-Plug Plug
N1254A-515	BNC-Jack-Plug-Jack
N1254A-516	BNC-Jack-Jack-Jack
N1254A-517	Adapter, Triaxial Jack to Triaxial Plug
N1254A-518	SHV Cable 1.5 m
N1254A-520	10 kV Ultra High Voltage Open End Cable, 1 m.
N1254A-521	10 kV Ultra High Voltage Jack to Jack Adapter
N1254A-522	1500 A Ultra High Current Banana to Banana Cable, 2 ea.
N1254A-523	1500 A Ultra High Current Banana to Open End Cable, 1 m, 2 ea

Order Information (continued)

B1505A accessories (continued)	
N1254A-524	Ultra High Current Prober System Cable
N1254A-525	SHV Cable Assy 1.5m - SHV Plug To Open-end
N1254A-526	Ultra High Current Cable, 2m, No Connectors At Either End
N1254A-527	PTFE Standoff, Jack, 4 ea.
N1254A-528	PTFE Standoff With Banana Plug, 4 ea.
N1254A-556	Test Leads and Connection Kit for Capacitance Test, 30 cm, 4 ea.
N1254A-557	Test Leads And Connection Kit For Thermal Test with N1271A
N1254A-558	SHV Cable 3m
N1258A	Module selector
N1260A	High voltage bias-tee
N1261A	Protection adapter
N1262A	Resistor box
N1262A-020	Universal R-Box, Triaxial
N1262A-021	Universal R-Box, HV Triaxial to SHV
N1262A-023	Universal R-Box for Ultra High Voltage
N1262A-036	50 Ohm Termination Adapter
SMU cables/accessories	
16493S-001	HCSMU cable (1.5 m)
16493S-002	HCSMU cable (3 m)
16493S-010	HCSMU Kelvin adapter
16493S-011	HCSMU non-Kelvin adapter
16493S-020	Dual HCSMU Kelvin combination adapter
16493S-021	Dual HCSMU combination adapter
16493T-001	High voltage triaxial cable (1.5 m)
16493T-002	High voltage triaxial cable (3 m)
16493U-001	High current BNC cable (1.5 m)
16493U-002	High current BNC cable (3 m)
16494A-001	Triaxial cable (1.5 m)
16494A-002	Triaxial cable (3 m)
16493K-001	Kelvin triaxial cable (1.5 m)
16493K-002	Kelvin triaxial cable (3 m)
16493V-001	10 kV Ultra High Voltage Cable, 1.5 m
16493V-002	10 kV Ultra High Voltage Cable, 3 m
N1269A	Ultra High Voltage Connection Adapter
CMU accessories	
N1300A-001	CMU cable (1.5 m)
N1300A-002	CMU cable (3 m)

Other accessories	
16493G-001	Digital I/O cable (1.5 m)
16493G-002	Digital I/O cable (3 m)
16493J-001	Interlock cable (1.5 m)
16493J-002	Interlock cable (3 m)
16493L-001	GNDU cable (1.5 m)
16493L-002	GNDU cable (3 m)
Retrofit and upgrade kits	
B1505AU	Upgrade kit for B1505A
B1505AU-001	Conversion kit from B1500A to B1505A
B1500AU-PC2	Mainframe upgrade (available for S/N starts with JP or less than MY53440000)
B1500AU-PC3	Mainframe upgrade (available for S/N MY53440101 or later)
B1505AU-010	High power source monitor unit (B1510A)
B1505AU-11B	Medium power source monitor unit (B1511B)
B1505AU-012	High current source monitor unit (B1512A)
B1505AU-13C	High voltage source monitor unit (B1513C)
B1505AU-014	Medium current source monitor unit (B1514A)
B1505AU-020	Multi frequency capacitance measurement unit (B1520A)
B1505AU-SWS	EasyEXPERT group+ Extension support and subscription
N1259AU	Upgrade kit for N1259A
N1265AU	Upgrade kit for N1265A
Package solution	
B1505AP	Pre-configured Power Device Analyzer/Curve Tracer (B1505A w/ modules/fixture)
B1505AP-H20	3 kV / 20 A / Fixture Pack
B1505AP-H21	3 kV / 20 A / C-V / Fixture Pack
B1505AP-H50	3 kV / 500 A / Fixture Pack
B1505AP-H51	3 kV / 500 A / C-V / Fixture Pack
B1505AP-H70	3 kV / 1500 A / Fixture Pack
B1505AP-H71	3 kV / 1500 A / C-V / Fixture Pack
B1505AP-U50	10 kV / 500 A / Fixture Pack
B1505AP-U70	10 kV / 1500 A / Fixture Pack

Learn more at: www.keysight.com

For more information on Keysight Technologies' products, applications or services, please contact your local Keysight office. The complete list is available at: www.keysight.com/find/contactus

