

2230G-30-3, 2230G-30-6, 2230G-60-3 High Power, 3-Channel Programmable Power Supplies

Datasheet



KEITHLEY
A Tektronix Company

The Series 2230G 3-channel programmable power supplies provide up to 375 W of power in a space-saving 2U high, half-rack width enclosure to power automotive circuits, LED drivers, power supplies, power ICs, and other high-power circuits. The 2230G-30-3 offers 195 W with two 30 V, 3 A channels and a 5 V, 3 A channel. The 2230G-30-6 and the 2230-60-3 supplies output as much as 375 W. The 2230G-30-6 provides two 30 V, 6 A channels, while the 2230G-60-3 has two 60 V, 3 A channels. Both 375 W supplies have a 5 V, 3 A channel as the third channel. These three supplies are linear power supplies; thus, they are low noise supplies to have minimal impact on a device-under-test (DUT). Each channel has a rectangular output characteristic to enable obtaining the full current at the maximum voltage so that the 2230G-30-6 can supply 30 V to a 6 A load and the 2230G-60-3 can supply 60 V to a 3 A load.

Key Features

- Choose from one 195 W model and two 375 W models
- 195 W model has two 30 V, 3 A channels and one 5 V, 3 A channel
- 375 W models have two 30 V, 6 A channels or two 60 V, 3 A channels and one 5 V, 3 A channel
- All channels are independently controlled and are isolated to power a wide range of test setups
- All channels have remote sensing so the programmed voltage is accurately applied to the load
- Set and monitor output voltages with 0.03% basic accuracy and 1 mV resolution
- Monitor load current with 0.1% basic accuracy and 1 mA resolution
- Low noise, linear regulation with <1 mV rms ripple and noise
- Combine channels in series to output as high as 60 V and in parallel with two or three channels to create capacity as high as 15 A (2230G-30-6)
- Voltage and current outputs of three channels are displayed simultaneously for immediate observation of each output state
- USB, GPIB, and RS-232 interfaces and rear panel connections for automated test convenience

Applications

Series 2230G power supplies are ideal for testing:

- High power analog ICs
- Automotive circuits
- Telecom infrastructure circuits
- LED driver circuitry

Isolated and independent outputs provide maximum flexibility

Each output channel of the Series 2230G high power supplies is both independent of the other channels and electrically isolated from the other channels. Therefore, these supplies can power circuits that are optically isolated or transformer-isolated from each other and have different reference points. The isolated channels eliminate the need for a second power supply to power one of the isolated circuits.

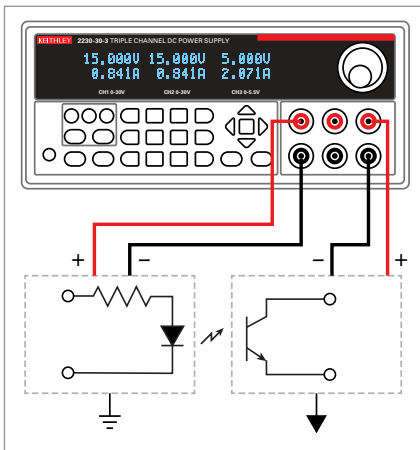

Power two isolated circuits with isolated output channels.

Furthermore, each channel can be independently controlled so that channels can be independently turned on and turned off at any time. These power supplies can power up a circuit with multiple voltage levels, such as a digital circuit with a 1.2 V microprocessor and FPGA, a 1.8 V memory, and 3.3 V digital I/O lines, in a sequence that safely brings up the lower voltages before the higher voltages are powered.

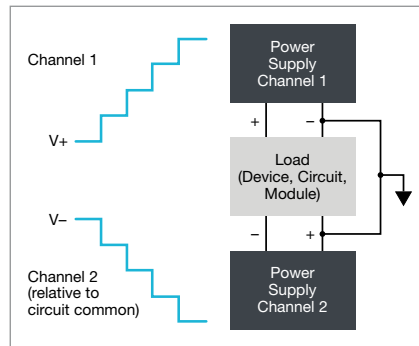

Use the tracking function to power a DUT's bipolar circuits and test the DUT over its specified operating voltage range.

Allowing control over each individual channel minimizes noise in the circuit. When a test requires only one or two channels, the unused channels can be turned off to minimize the total output noise. Thus, circuits that are sensitive to noise on their DC power lines can be powered with the minimum output noise from the Series 2230G power supplies.

Combine the two 30 V outputs of the 2230G-30-3 and the 2230G-30-6 in series to output up to 60 V with either 3 A or 6 A load current capacity. When higher load current is needed, either two or all three channels of each supply can be combined in parallel. The 2230G-30-6 can supply 12 A from its two 30 V channels. If the

test circuit requires only a maximum of 5 V, then all three channels can be connected in parallel to supply up to 15 A. The Series 2230G supplies have display and control functions to simplify the task of combining channels in series and parallel. The display indicates whether the series or parallel mode has been selected and shows the total series voltage or parallel current output. The supply also manages the channels to ensure that each channel outputs an equivalent value.

For powering bipolar analog circuits, channels 1 and 2, the 30 V and 60 V channels of the Series 2230G supplies can be connected to power a positive and a negative circuit. The supplies have a tracking mode so that the outputs of both supplies can be simultaneously changed with one control operation. The magnitudes of the two tracked channels either change together or change in a user-defined ratio when the voltage is changed. Thus, a bipolar circuit, module, or device can be easily tested over its specified voltage operating range.

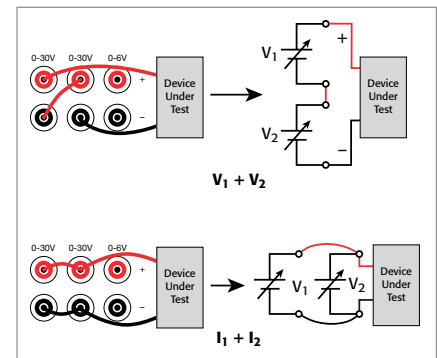

Combine 30V channels in series to extend voltage output to 60 V. Combine channels in parallel to extend current output capacity. For example, combine all three channels of a 2230G-30-6 to output up to 15 A.

Deliver accurate voltages to the load

The setting and measurement basic voltage accuracy of each channel is 0.03%; and the setting and measurement resolution is 1 mV. Thus, the user can be confident that the programmed output is accurately applied to the output terminals. In addition, using the remote sense leads for each channel ensures that the programmed voltage is applied to the load; the remote sense leads compensate for and overcome the voltage drops due to the resistances in the test leads.

Convenience features simplify manual operation

The Series 2230G high power supplies have valuable features that enable easy use for manual testing.

- When the outputs are off, the display shows the previously programmed voltage and current settings. This ensures that an incorrect output is not applied to a DUT when the outputs are turned on.
- The displays for all three channels are shown so each channel's output is always visible to give the user immediate feedback on the status of the DUT.
- Output voltages can be controlled by the rotary knob or with the numeric keypad to test DUT response to large changes or small changes.
- Save the setup parameters for tests that are performed repetitively in one of 36 memory locations and save time reproducing each test. Front panel Save and Recall buttons make saving and recalling a setup an easy operation to perform.

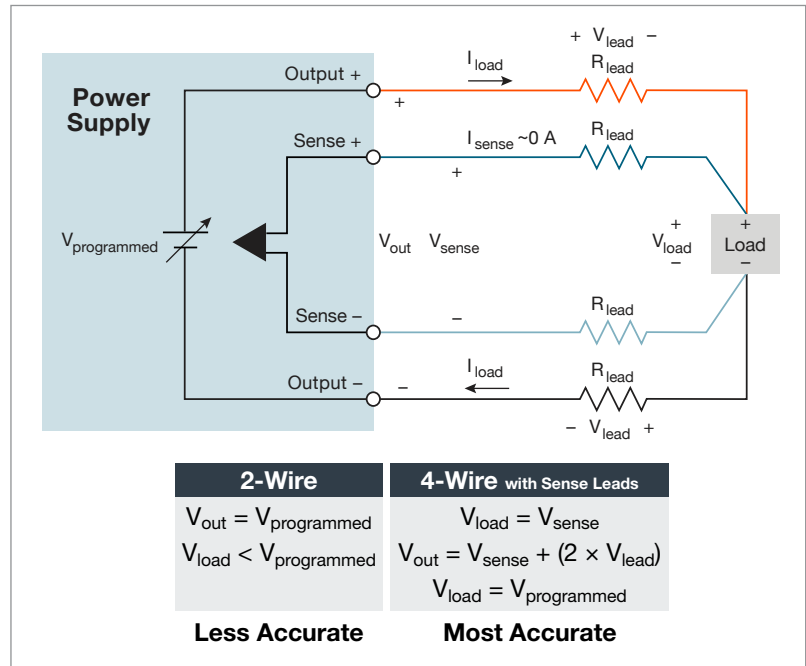

Each channel of a Series 2230G supply has remote sense inputs that ensure that the programmed voltage is accurately applied to the load.

Protection for your DUT in both manual and automated operation

The Series 2230G supplies have a set of features designed to protect the DUT. Each channel has a maximum voltage setting that prevents the output voltage from being accidentally adjusted above a programmed limit. Independent outputs allow a different limit to be programmed for each output channel. Also, a user-definable password allows the front panel to be locked to prevent any changes in parameters during testing. For unattended testing, programmable timers on each channel can turn the outputs off after a test has been completed. This ensures that a DUT that is not yet fully temperature controlled does not overheat due to the application of continuous power.

Save space and minimize test lead length in automated test systems

Even though the Series 2230G supplies can output 195 W and 375 W and are linear, low noise sources, they are only 2 U high and half-rack wide. The compact size helps to minimize the size of a test system by saving valuable rack space. In addition, the Series 2230G supplies have both front and rear output connections so that test lead wires from the supplies can be as short as possible. If the rear panel output connections are used, then the test leads are protected from accidental contact to improve test system reliability.



2230G-HRM Harmonic Reduction Module reduces AC power line current harmonics when inserted between the power supply and the power outlet. The 2230G-HRM is required for compliance to standard EN 61000-3-2 in EU countries and is needed for the 2230G-30-6 and 2230G-60-3.

Test automation options

The Series 2230G supplies have three standard interface options for PC control, USB, GPIB, and RS-232. Either interface enables complete control of the supply. LabView and IVI drivers, downloadable from www.tek.com, facilitate instrument control, data logging, and analysis. With these drivers, the power supplies can be controlled from most commercially-available software packages such as MatLab. With a software package and drivers, the supplies can be controlled in either a semi-automated or a fully-automated test system.



Series 2230G power supplies rear panel showing the USB, GPIB, and RS-232 interfaces and the rear output, source, and sense lead terminal block for all three channels.

Specification Conditions

Specifications are the standards against which the 2230G-30-3, 2230G-30-6, and 2230G-60-3 are tested. Upon leaving the factory, the 2230G-30-3, 2230G-30-6, and 2230G-60-3 meet these specifications. Typical values are not warranted, apply at 23°C ± 5°C, and are provided solely as useful information. Specifications apply under these conditions:

- Temperature 0°C to 40°C and relative humidity 10% to 80% unless defined differently in this document.
- After a 30-minute warmup period.
- Within one year of the calibration period.

Model-Specific Specifications

	2230G-30-3		2230G-30-6		2230G-60-3	
	CH 1 and CH 2	CH 3	CH 1 and CH 2	CH 3	CH 1 and CH 2	CH 3
DC Output Rating						
Voltage	0 V to 30 V	0 V to 5 V	0 V to 30 V	0 V to 5 V	0 V to 60 V	0 V to 5 V
Voltage Limit	30.1 V	5.1 V	30.1 V	5.1 V	60.1 V	5.1 V
Current	0 A to 3 A	0 A to 3 A	0 A to 6 A	0 A to 3 A	0 A to 3 A	0 A to 3 A
Maximum power	195 W		375 W		375 W	
Load Regulation						
Voltage	≤0.01% + 3 mV		≤0.01% + 3 mV		≤0.01% + 3 mV	
Current	≤0.01% + 3 mA		≤0.01% + 3 mA		≤0.01% + 3 mA	
Line Regulation						
Voltage	≤0.01% + 3 mV		≤0.01% + 3 mV		≤0.01% + 3 mV	
Current	≤0.01% + 3 mA		≤0.01% + 3 mA		≤0.01% + 3 mA	
Ripple and Noise (20 Hz to 20 MHz, 23°C ± 5°C)						
Voltage ($V_{\text{peak-peak}}$)	3 mV _{peak-peak}		4 mV _{peak-peak}	3 mV _{peak-peak}	4 mV _{peak-peak}	
Voltage (VRMS)	1 mV _{RMS}		1 mV _{RMS}	1 mV _{RMS}	1 mV _{RMS}	
Current (IRMS)	4 mA		5 mA	4 mA	4 mA	
Setting Resolution						
Voltage	1 mV		1 mV		1 mV	
Current	1 mA		1 mA		1 mA	
Setting Accuracy (using remote sense, 23°C ± 5°C)						
Voltage	≤0.03% + 10 mV		≤0.03% + 10 mV		≤0.03% + 10 mV	
Current	≤0.1% + 5 mA		≤0.1% + 8 mA	≤0.1% + 5 mA	≤0.1% + 5 mA	
Readback Resolution						
Voltage	1 mV		1 mV		1 mV	
Current	1 mA		1 mA		1 mA	
Readback Accuracy (23°C ± 5°C)						
Voltage	≤0.03% + 10 mV		≤0.03% + 10 mV		≤0.03% + 10 mV	
Current	≤0.1% + 5 mA		≤0.1% + 8 mA	≤0.1% + 5 mA	≤0.1% + 5 mA	
Temperature Coefficient ±(% of output + offset)/°C						
Voltage	≤0.01% + 1 mV		≤0.01% + 1 mV		≤0.01% + 1 mV	
Current	≤0.02% + 1 mA		≤0.02% + 1 mA		≤0.02% + 1 mA	
Series Setting Resolution						

	2230G-30-3		2230G-30-6		2230G-60-3	
	CH 1 and CH 2	CH 3	CH 1 and CH 2	CH 3	CH 1 and CH 2	CH 3
Voltage	1 mV	—	1 mV	—	—	—
Current	1 mA	—	1 mA	—	—	—
Series Readback Resolution						
Voltage	1 mV	—	1 mV	—	—	—
Current	1 mA	—	1 mA	—	—	—
Parallel Setting Resolution						
Voltage	1 mV	—	1 mV	—	1 mV	—
Current	1 mA	—	0–9.999A: 1 mA 10–12A: 10 mA	—	1 mA	—
Parallel Readback Resolution						
Voltage	1 mV	—	1 mV	—	1 mV	—
Current	1 mA	—	0–9.999A: 1 mA 10–12A: 10 mA	—	1 mA	—
Rise Time (10% to 90%)	≤100 ms		≤100 ms		≤100 ms	
Fall Time (90% to 10%)	≤0.5 s	≤0.1 s	≤0.5 s	≤0.1 s	≤1.5 s	≤0.1 s
Load Transient Recovery Time						
Voltage setting band 50 mV, 50% to 100%, 1 kHz, rise and fall rate 5 A per μs: ≤50 μs (typical)						
Transition Time						
CC mode to CV mode, V-set = 5 V, I-limit = 0.5 A, resistive load change from 2.5 Ω to 25 Ω: ≤10 ms						
CV mode to CC mode, V-set = 5 V, I-limit = 0.5 A, resistive load change from 25 Ω to 2.5 Ω: ≤5 ms						
Output Timer						
Setting Range	0.1 s to 99999.9 s		0.1 s to 99999.9 s		0.1 s to 99999.9 s	
Resolution	0.1 s		0.1 s		0.1 s	

General Specifications

Communications	<p>USB: Type A to B connector, USB 2.0, USBTMC compatible</p> <p> GPIB: IEEE Std 488.2 compliant</p> <p>RS232: Baud Rates: 4800/9600/19,200/38,400/57,600/115,200</p>
Rear-Panel Connectors	<p>Output: 15-pin terminal block socket</p> <p>RS-232: DB-9 connector</p> <p>USB Device: Type B connector</p> <p>GPIB: IEEE-compliant 24-pin connector</p> <p>AC Power Input: 3-prong socket assembly with fuse</p>
Display	Vacuum fluorescent display
Memory	36 setup memories
Output and Remote Sense	<p>Removable 15-15-pin screw-terminal block carries the following signals:</p> <p>Output Channels: Duplicates the front-panel outputs</p> <p>Remote Sense Lines: Connections for remote sense for each channel</p>
Floating Voltage Rating	Up to 400 V (DC + peak AC) between protective earth (safety ground) and any output terminal
Power Source	<p>110 V AC Setting: 99 V_{RMS} to 132 V_{RMS} 108 V_{RMS} to 132 V_{RMS} (2230G-30-6 and 2230G-60-3 with 2230G-HRM installed)</p> <p>220 V AC Setting: 198 V_{RMS} to 264 V_{RMS}</p> <p>Frequency: 50/60 Hz</p> <p>Power Consumption: 2230G-30-3: 700 VAC; 2230G-30-6, 2230G-60-3: 1000 VAC</p>
EMC	<p>European Union: Conforms to European Union EMC directive</p> <p>USA: FCC, CFR Title 47, Part 15, Subpart B, Class A</p> <p>Australia: EMC Framework, demonstrated per Emission Standard AS/NZS 2064 (industrial, scientific, and medical equipment)</p>
Safety	<p>European Union: Conforms to Low Voltage Directive</p> <p>USA: NRTL listed to UL61010-1-2004</p> <p>Canada: CAN/CSA C22.2 No. 61010-1 2004</p>
Dimensions	<p>With boot: 104.2 mm high × 225.3 mm wide × 481.1 mm deep (4.10 in. × 8.87 in. × 18.94 in.)</p> <p>Without boot: 88.2 mm high × 214.5 mm wide × 456.6 mm deep (3.47 in. × 8.44 in. × 17.98 in.)</p>
Shipping Weight	<p>2230G-30-3: 12.3 kg (27 lb.)</p> <p>2230G-30-6, 2230G-60-3: 13.8 kg (30 lb.)</p>
Net Weight	<p>2230G-30-3: 9.6 kg (21 lb.)</p> <p>2230G-30-6, 2230G-60-3: 11.1 kg (24 lb.)</p>
Environment	<p>Altitude:</p> <p> Operating: Up to 2000 meters (6562 ft) above sea level</p> <p> Storage: Up to 4000 meters (13124 ft) above sea level</p> <p>Operating: 0 °C to 40 °C, 10% to 80% relative humidity up to 40°C</p> <p>Storage:</p> <p> –20°C to 70°C, 10% to 80% relative humidity up to 40°C</p> <p> –20°C to 70°C, 5% to 60% relative humidity above 40°C up to 70°C</p>

Ordering Information

2230G-30-3	Programmable 3-Channel Power Supply, 195 W, Two 30 V, 3 A Channels, One 5 V, 3 A Channel
2230G-30-6	Programmable 3-Channel Power Supply, 375 W, Two 30 V, 6 A Channels, One 5 V, 3 A Channel
2230G-60-3	Programmable 3-Channel Power Supply, 375 W, Two 60 V, 3 A Channels, One 5 V, 3 A Channel

Supplied Accessories

2230G-903-01A	Quick Start Guide
016214000	2230G-HRM Harmonic Reduction Module (for 2230G-30-6 and 2230G-60-3)
116128300	Screw Terminal Block, 15 Terminals
174684100	USB Cable, 1.5 m (4.9 ft)
174717200	Line Cord (for 2230G-30-6 and 2230G-60-3)
	Power Cord (See Power Cord Options)
	Traceable Calibration Certificate
	Three-Year Warranty
	User Manual, LabView and IVI Drivers available on www.tek.com/2230g-highpower

Power Cord Options

A0	North America power plug (120 V, 60 Hz)
A1	Universal Euro power plug (220 V, 50 Hz)
A2	United Kingdom power plug (240 V, 50 Hz)
A3	Australia power plug (240 V, 50 Hz)
A4	Chile, Italy (220 V, 50 Hz)
A5	Switzerland power plug (220 V, 50 Hz)
A7	Denmark
A8	Israel
A9	Argentina
A10	China power plug (50 Hz)
A11	India power plug (50 Hz)
A99	No power cord
E1	Europe Bundle: Mainland Europe, UK, Switzerland and Liechtenstein power cords (3)

Available Accessories

116128300	Screw Terminal Block, 15 Terminals
4299-7	Universal Rack Mount Shelf Kit
7007-1	Shielded GPIB Cable, 1 m (3.2 ft)
7007-2	Shielded GPIB Cable, 2 m (6.5 ft)
KPCI-488LPA	IEEE-488 Interface for PCI Bus
KUSB-488B	IEEE-488 USB-GPIB Interface Adapter
USB-B-1	USB Cable, 1 m (3.2 ft)

Available Services

Model Number*-EW	1 Year KeithleyCare Gold Plan, extends warranty one additional year
Model Number-5Y-EW	5 Year KeithleyCare Gold Plan, extends 3-year warranty to 5 years
C/Model Number-3Y-STD	3 Year KeithleyCare Standard Calibration Plan, 3 calibrations within 3 years
C/Model Number-5Y-STD	5 Year KeithleyCare Standard Calibration Plan, 5 calibrations within 5 years
C/Model Number-3Y-DATA	3 Year KeithleyCare 3 Calibration Plan with Data, 3 calibrations within 3 years with Z540 data report
C/Model Number-5Y-DATA	5 Year KeithleyCare Calibration Plan with Data, 5 calibrations within 5 years with Z540 data report

Replace "Model Number" with a Series 2230G model number. For example, if the 2230G-30-3 is selected, then the part number for the 1 Year KeithleyCare Gold Plan is 2230G-30-3-EW.

Contact Information:

Australia 1 800 709 465
Austria* 00800 2255 4835
Balkans, Israel, South Africa and other ISE Countries +41 52 675 3777
Belgium* 00800 2255 4835
Brazil +55 (11) 3759 7627
Canada 1 800 833 9200
Central East Europe / Baltics +41 52 675 3777
Central Europe / Greece +41 52 675 3777
Denmark +45 80 88 1401
Finland +41 52 675 3777
France* 00800 2255 4835
Germany* 00800 2255 4835
Hong Kong 400 820 5835
India 000 800 650 1835
Indonesia 007 803 601 5249
Italy 00800 2255 4835
Japan 81 (3) 6714 3086
Luxembourg +41 52 675 3777
Malaysia 1 800 22 55835
Mexico, Central/South America and Caribbean 52 (55) 56 04 50 90
Middle East, Asia, and North Africa +41 52 675 3777
The Netherlands* 00800 2255 4835
New Zealand 0800 800 238
Norway 800 16098
People's Republic of China 400 820 5835
Philippines 1 800 1601 0077
Poland +41 52 675 3777
Portugal 80 08 12370
Republic of Korea +82 2 565 1455
Russia / CIS +7 (495) 6647564
Singapore 800 6011 473
South Africa +41 52 675 3777
Spain* 00800 2255 4835
Sweden* 00800 2255 4835
Switzerland* 00800 2255 4835
Taiwan 886 (2) 2656 6688
Thailand 1 800 011 931
United Kingdom / Ireland* 00800 2255 4835
USA 1 800 833 9200
Vietnam 12060128

* European toll-free number. If not accessible, call: +41 52 675 3777

Rev. 02.2018



Find more valuable resources at TEK.COM

Copyright © Tektronix. All rights reserved. Tektronix products are covered by U.S. and foreign patents, issued and pending. Information in this publication supersedes that in all previously published material. Specification and price change privileges reserved. TEKTRONIX and TEK are registered trademarks of Tektronix, Inc. All other trade names referenced are the service marks, trademarks or registered trademarks of their respective companies.
092820.SBG 1KW-61421-1

