



**REAL TIME CROSS CORRELATION**



**RoHS**

# **HA7062D**

## **PHASE NOISE ANALYZER**

**10MHz to 26GHz**

**Optional to 40GHz**

**Cross Correlation**

**Real Time Data Acquisition**

**PRELIMINARY DATA SHEET**

**OCTOBER 2018**

 **holzworth**  
instrumentation

### PRODUCT SUMMARY

The **HA7062D Real Time Phase Noise Analyzer** is born from Holzworth's history of industry leading phase noise analyzers with proven accuracy, high reliability, automation and flexibility. The real time engine covers the full measurement bandwidth with extremely fast measurement speeds to reduce product development time and optimizes ATE manufacturing throughput.

**MEASURED NOISE FLOORS:** Like the HA7062D, competitive designs provide a *measurement confidence factor*, which is often misinterpreted as the noise floor of the instrument. Holzworth is the only company that has architected the instrument's front end so that the noise floors limits can actually be measured (refer to pages 7-10).

**UNPARALLELED ANALOG PERFORMANCE:** The HA7062D has high speed digital processors for speed, but the proven accuracy and speed starts with the analog front end. A key component of the analog front end is a pair of Holzworth HSX Series RF Synthesizers as the test system's internal LOs. These ultra low noise RF sources not only complement the dual core FFT engine to provide one of the most advanced phase noise analyzers available, but they are also made available to the user at the front panel's *LO Output* ports.

**REPEATABLE DATA:** Holzworth's fully shielded, fan-less 1U chassis eliminates ground loops and troublesome microphonics for uncompromised performance and repeatability. See it for yourself knowing that Holzworth encourages running head-head tests with the competition. Contact Holzworth directly for availability of an evaluation unit in your area.

### **REAL TIME FULL BANDWIDTH DATA ACQUISITION**

**ANSI Z540 CALIBRATED ACCURACY 0.1Hz - 100MHz**

### **VERSATILE - RECONFIGURABLE FRONT END**

**MEASURE: PM / AM / BASEBAND / SPURIOUS / JITTER / PULSE**

**SIMULTANEOUS/ ISOLATED AM/PM MEASUREMENTS**

**AUTOMATED RESIDUAL MEASUREMENTS**

**MEASURABLE ULTRA LOW PHASE NOISE FLOORS**

**3 YEAR MANUFACTURER WARRANTY**



**PRODUCT SUMMARY - BLOCK DIAGRAM**

**VERSATILE:** The HA7062D is a result of more than a decade of product development reflecting valuable customer feedback and Holzworth’s direct experience with measuring phase noise in our own manufacturing environment. The end result goes well beyond accuracy, reliability and speed... the reconfigurable front end allows users to tailor the analyzer for their specific measurement needs.

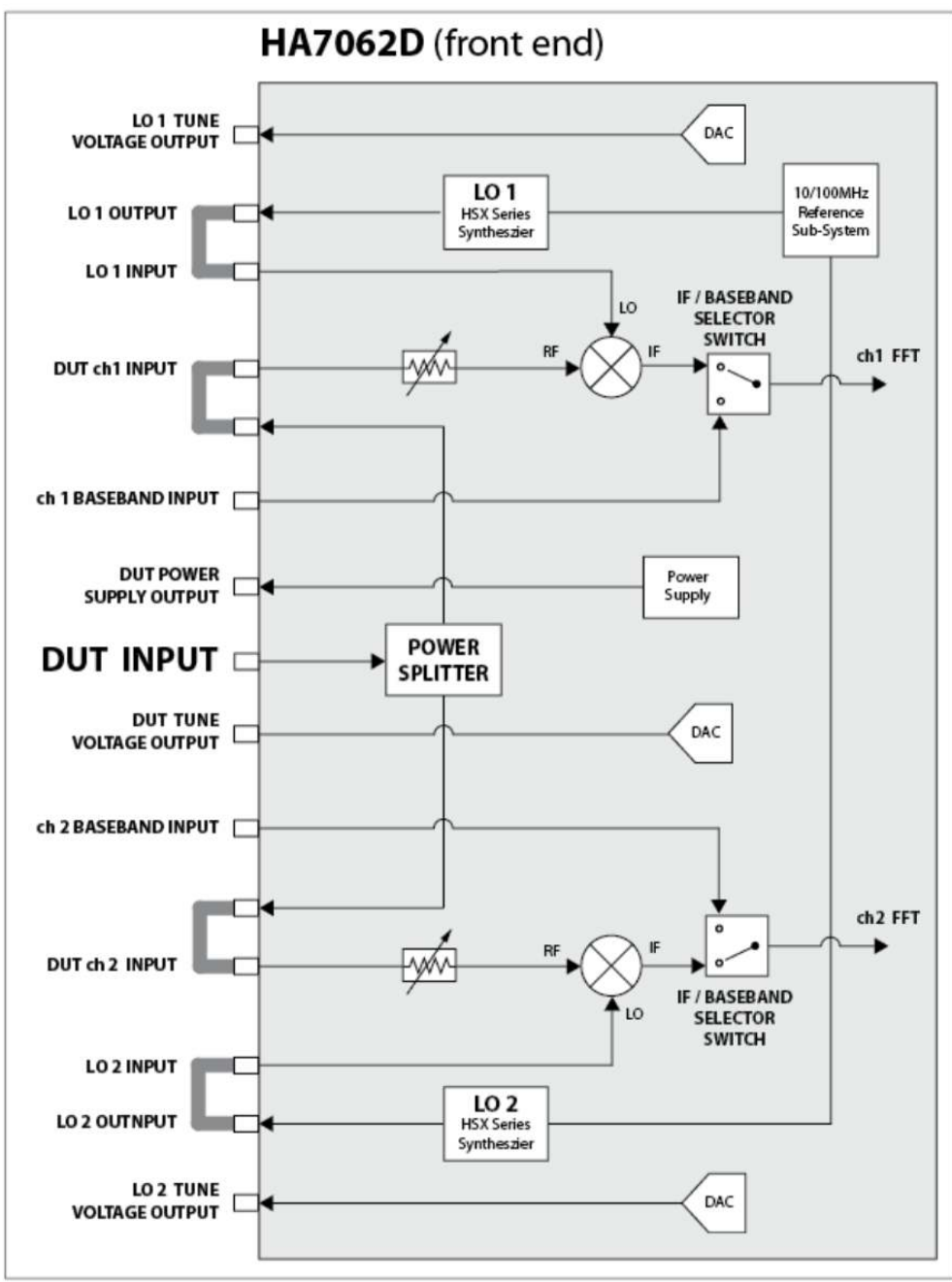


Figure 1: HA7062D Front End Block Diagram

**SPECIFICATIONS - ELECTRICAL**

The specifications outlined here capture the baseline performance and features that are currently available from the HA7062D phase noise analyzer. The highly reliable hardware is capable of additional functionality for custom requirements. Inquire with Holzworth Instrumentation or your local sales representative.

**RF INPUT (DUT/LO)**

| DESCRIPTION                         | SPECIFICATION   |
|-------------------------------------|---|
| RF Input Connector                  | 2.92mm (female), 50 ohm                                       |
| RF Input Frequency Range (standard) | 10MHz to 26GHz  |
| RF Frequency Extension (40GHz)      | Available 2019  |
| RF Input Measurement Level          | -5dBm to +20dBm (Holzworth pre-amplifier available for <0dBm) |
| Input Damage Level                  | +22dBm  |
| Input VSWR                          | < 2.0:1   |

**PHASE NOISE MEASUREMENTS**

| DESCRIPTION   | SPECIFICATION   |
|---|---|
| RF Input Frequency Range  | 10MHz to 26GHz  |
| RF Frequency Extension (40GHz)  | Option: OPT-CC40 (available 2019)   |
| RF Tracking Range   | $\pm 10$ ppm (typical), $\pm 5$ ppm (specified)   |
| Offset Frequency Range  | 0.1 Hz – 100 MHz (ANSI z540.1)  |
| Phase Noise Uncertainty<br>1 Hz to 1 kHz offset<br>1 kHz to 1 MHz offset<br>1 MHz to 100 MHz offset | $\pm 4$ dB (to be updated with improved uncertainty resulting from z540.1 calibration statistics)<br>$\pm 2$ dB (to be updated with improved uncertainty resulting from z540.1 calibration statistics)<br>$\pm 2$ dB (to be updated with improved uncertainty resulting from z540.1 calibration statistics) |
| Cross-Correlation Noise Floor   | Refer to pages 7-10 for measured noise floor data   |

**SPECIFICATIONS - ELECTRICAL (continued)**
**TABLE 1: MEASUREMENT SPEED (SAMPLE TIME) vs. MINIMUM OFFSET**

| 1 Cross-Correlation |     |             |     |             |     |              |      |
|---------------------|-----|-------------|-----|-------------|-----|--------------|------|
| 128 Samples         |     | 256 Samples |     | 512 Samples |     | 1024 Samples |      |
| -                   | -   | 0.1Hz       | 32s | 0.1Hz       | 60s | 0.1Hz        | 112s |
| 1Hz                 | 12s | 1Hz         | 18s | 1Hz         | 33s | 1Hz          | 61s  |
| 10Hz                | 6s  | 10Hz        | 8s  | 10Hz        | 13s | 10Hz         | 22   |
| 100Hz               | 4s  | 100Hz       | 5s  | 100Hz       | 7s  | 100Hz        | 10s  |
| 1kHz                | 4s  | 1kHz        | 4s  | 1kHz        | 6s  | 1kHz         | 8s   |
| 10kHz               | 4s  | 10kHz       | 4s  | 10kHz       | 5s  | 10kHz        | 7s   |
| 100kHz              | 4s  | 100kHz      | 4s  | 100kHz      | 5s  | 100kHz       | 6s   |
| 1MHz                | 4s  | 1MHz        | 4s  | 1MHz        | 4s  | 1MHz         | 5s   |

| 10 Cross-Correlations |     |             |      |             |      |              |      |
|-----------------------|-----|-------------|------|-------------|------|--------------|------|
| 128 Samples           |     | 256 Samples |      | 512 Samples |      | 1024 Samples |      |
| -                     | -   | 0.1Hz       | 186s | 0.1Hz       | 370s | 0.1Hz        | 732s |
| 1Hz                   | 67s | 1Hz         | 96s  | 1Hz         | 189s | 1Hz          | 371s |
| 10Hz                  | 19s | 10Hz        | 28s  | 10Hz        | 52s  | 10Hz         | 100s |
| 100Hz                 | 6s  | 100Hz       | 8s   | 100Hz       | 13s  | 100Hz        | 20s  |
| 1kHz                  | 4s  | 1kHz        | 5s   | 1kHz        | 7s   | 1kHz         | 9s   |
| 10kHz                 | 4s  | 10kHz       | 4s   | 10kHz       | 6s   | 10kHz        | 8s   |
| 100kHz                | 4s  | 100kHz      | 4s   | 100kHz      | 6s   | 100kHz       | 7s   |
| 1MHz                  | 4s  | 1MHz        | 4s   | 1MHz        | 5s   | 1MHz         | 6s   |

**TABLE 2: CROSS-CORRELATIONS vs. PHASE NOISE IMPROVEMENT**

Improvement factor: dB = 5logN (N = No. of correlations)

| Number of Correlations | 1   | 10  | 100  | 1,000 | 10,000 |
|------------------------|-----|-----|------|-------|--------|
| dB Improvement         | 0dB | 5dB | 10dB | 15dB  | 20dB   |

**INTERNAL TIME BASE (10MHz Reference)**

| DESCRIPTION                       | SPECIFICATION  |
|-----------------------------------|--|
| Frequency Uncertainty / Stability | < ± 1Hz at 10MHz (±100 ppb) At time of shipment. Factory calibrated at +21C. |
| Frequency Temperature Effects     | < 10ppb  |
| Frequency Aging Rate              | < 100ppb/yr  |
| 10MHz External Lock Range         | ± 20Hz (typical), ± 10Hz (specified). 10MHz is for frequency counters only.  |

**SPECIFICATIONS - ELECTRICAL (continued)**
**POWER METER ACCURACY**

| PARAMETER                  | MIN | TYPICAL | MAX  | COMMENTS |
|----------------------------|-----|---------|------|----------|
| Input Power Meter Accuracy |     | ±0.25dB | ±2dB |          |

**ANSI z540 CALIBRATION**

| DESCRIPTION               | SPECIFICATION                                    |
|---------------------------|--|
| Frequency Offset Range    | 0.1Hz - 100MHz                                   |
| DUT Frequency Input Range | 10MHz - 26GHz Standard<br>10MHz - 40GHz Optional |

**MEASUREMENT MODES**

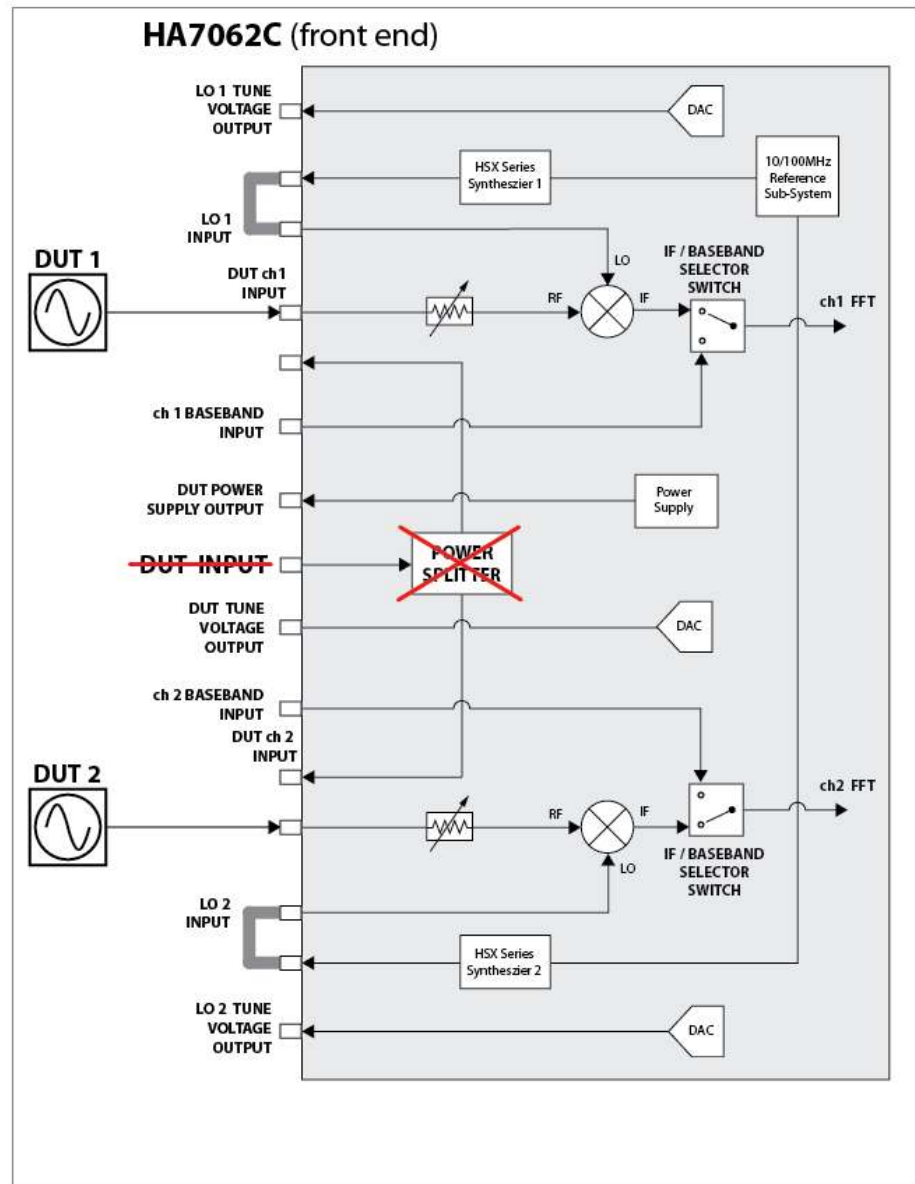
| MODE                       | DESCRIPTION   |
|----------------------------|---|
| Internal LO Mode           | Internal synthesized LO sources. Auto tune and phase lock.                        |
| External LO Mode           | User supplied LO sources. Auto calibration of LO sources and auto phase lock.     |
| Additive Mode              | External Signal Source required. Use with model HX5100-x Automated Phase Shifters |
| AM Noise Measurements      | Measure AM Noise to observe potential AM to PM conversion                         |
| Pulsed Signal Measurements | Sample and Hold feature allows for non-triggered pulse measurements               |
| Spurious Analysis Toolbox  | Provides spurious performance data based on a user settable Spur Threshold        |

### NOISE FLOOR MEASUREMENT SETUP

The unique architecture of the HA7062D allows for direct access to key internal modules in order to measure the actual noise floor of the analyzer at any given frequency vs. minimum frequency offset and number of correlations. As with Holzworth, competitive phase noise analyzers offer a cross correlation confidence factor, which is an only approximation based on the data being taken at the time. The confidence factor is not the actual noise floor of the system.

To perform a noise floor measurement, the internal power splitter is bypassed to directly access the phase detector (mixer) of each channel/core while measuring two non-correlated frequency sources at the frequency of interest. Refer to Figure 2, below.

**NOISE FLOOR**



**Figure 2: HA7062D Noise Floor Measurement Block Diagram**

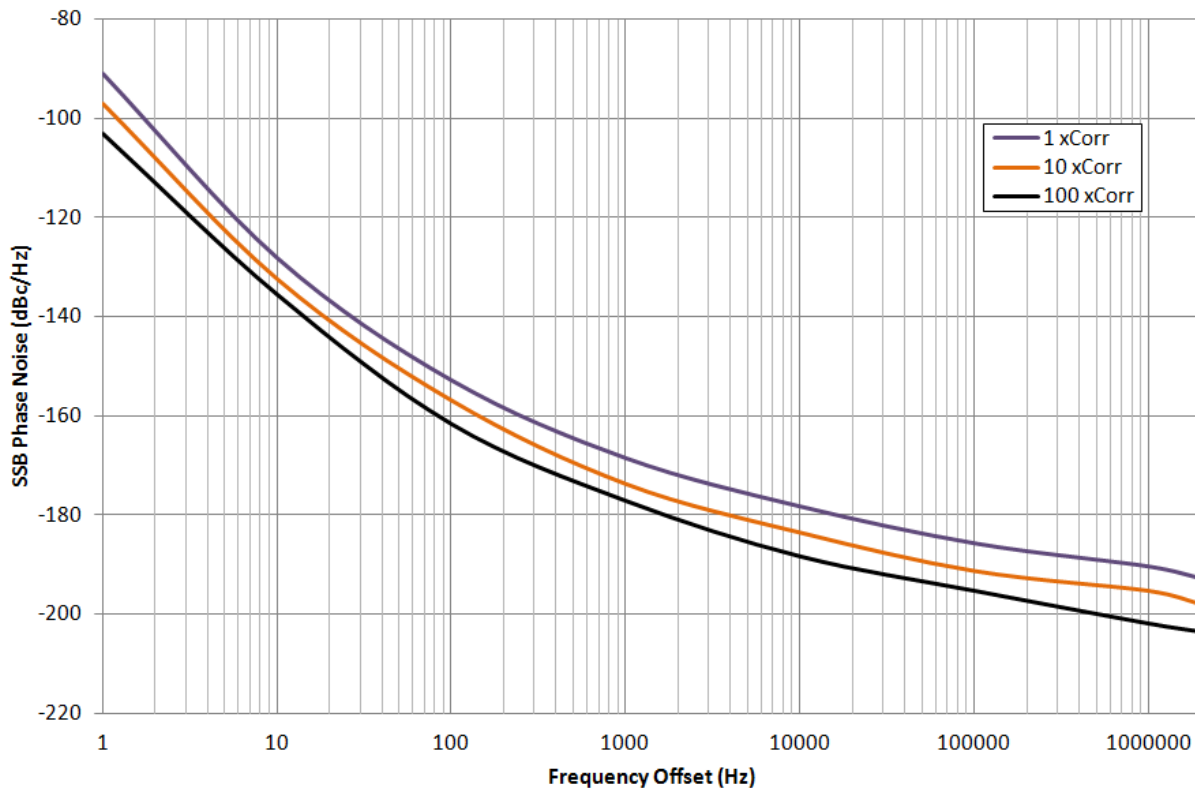
### NOISE FLOOR DATA

The data contained in this section demonstrates the noise floor capability of the HA7062D at five different frequencies covering the base operating range of the instrument (10MHz, 100MHz, 1GHz, 3GHz and 6GHz). The three plots in each figure reflect the actual noise floor for 1, 10 or 100 correlations. Further improvement in the noise floor can be achieved by utilizing more correlations (refer to Table 2, located on page 5).

All data contained in this section was acquired using a minimum offset frequency of 1Hz. For reference, the data acquisition times for each measurement are as follows:

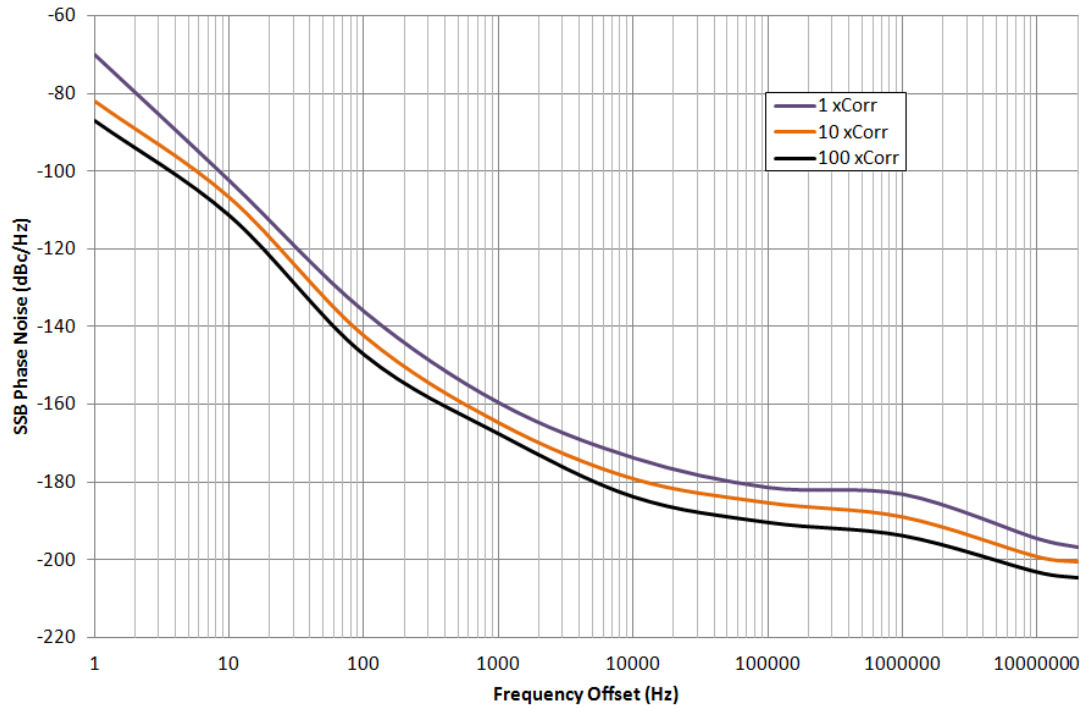
- 1 correlation: < 10s**
- 10 correlations: < 90s**
- 100 correlations: < 15 min**

**NOTE:** Setting the instrument to a higher minimum offset frequency will further improve the measurement speed.

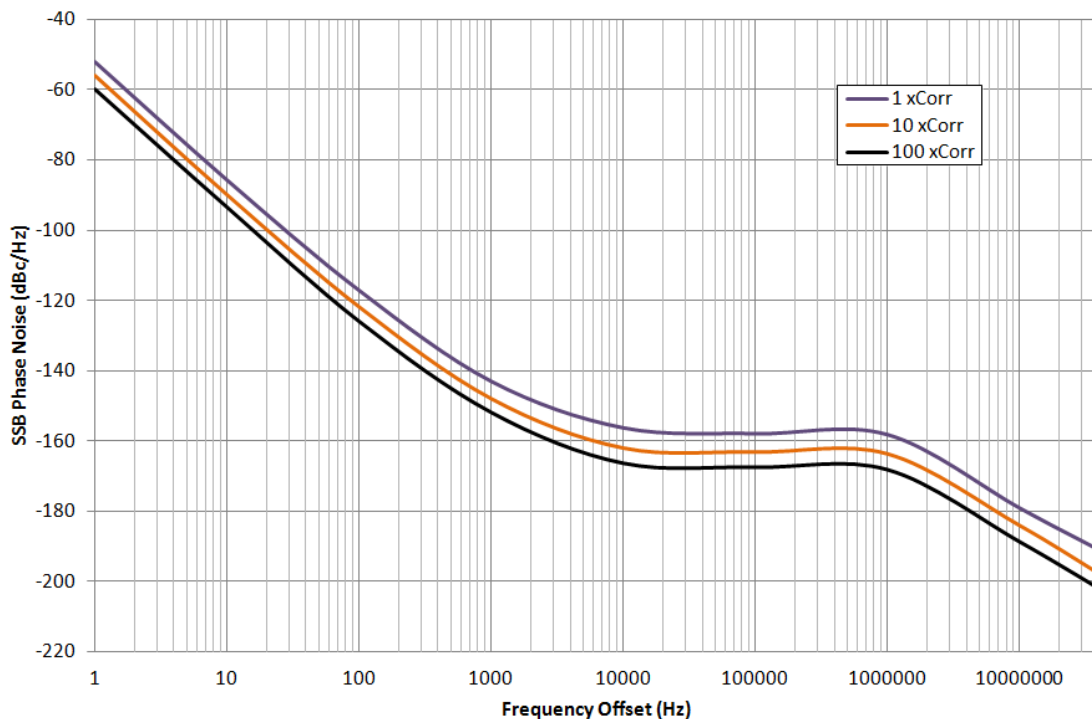


**Figure 3: 10MHz Noise Floor Measurements**

**NOISE FLOOR DATA (continued)**



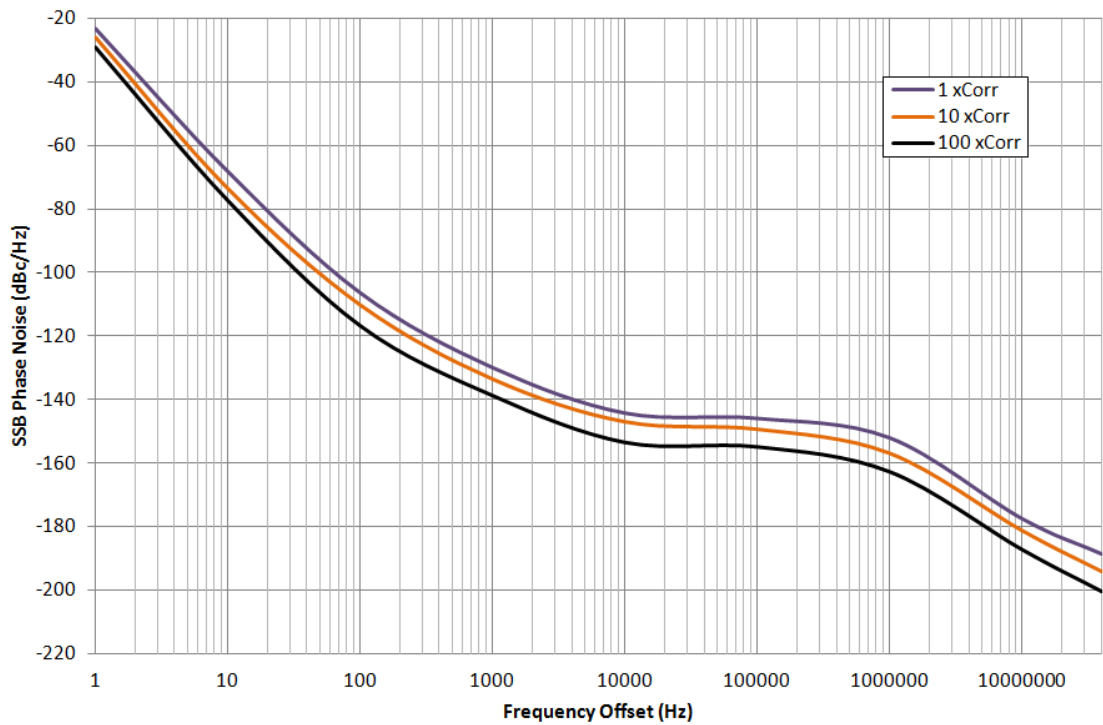
**Figure 4: 100MHz Noise Floor Measurements**



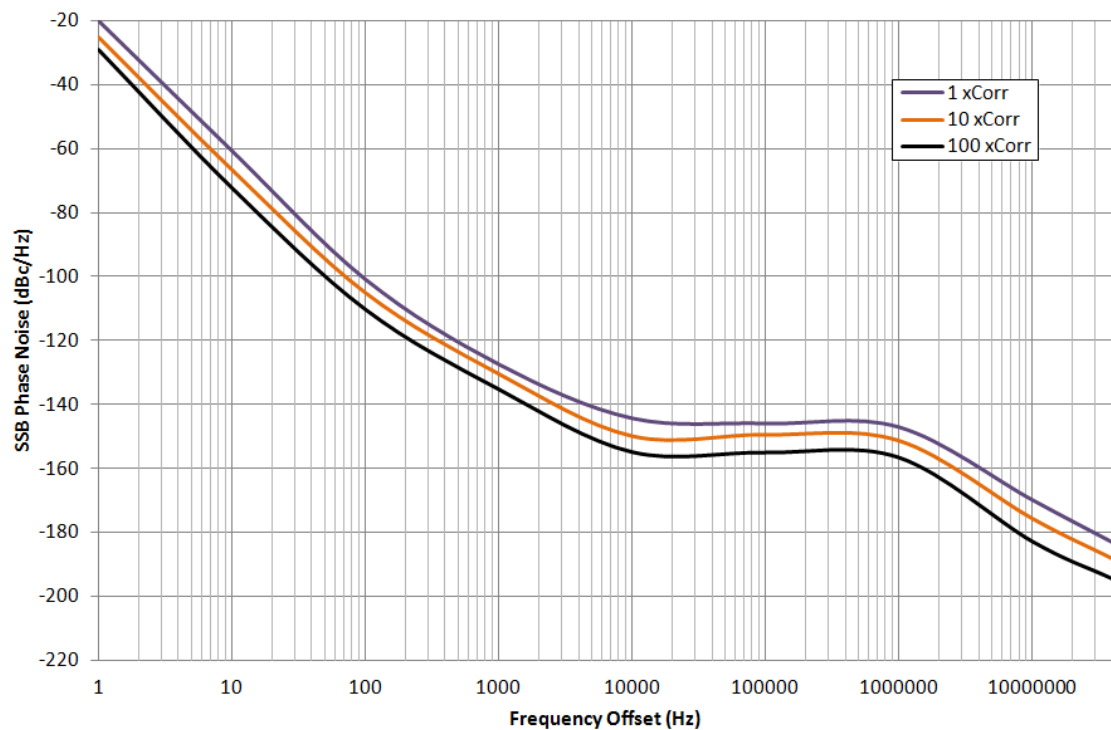
**Figure 5: 1GHz Noise Floor Measurements**

**NOISE FLOOR**

**NOISE FLOOR DATA (continued)**



**Figure 6: 3GHz Noise Floor Measurements**



**Figure 7: 6GHz Noise Floor Measurements**

**NOISE FLOOR**

### CONFIGURATION

#### FRONT PANEL

The HA7062D allows for a high level of measurement flexibility to accommodate different test scenarios by allowing the user access to various system input points. However, only the *DUT Input* port is necessary for making straight forward absolute phase noise measurements of a frequency source.

| DESCRIPTION   | SPECIFICATION   |
|---|---|
| Front Panel Connector(s) Type   | 2.92mm, 50ohm   |
| DUT Input<br>Frequency Range (standard)<br>Power Level Range<br>Input Damage Level            | 10MHz to 26GHz      10MHz to 40GHz (OPT-CC40)<br>-5dBm to +20dBm<br>+22dBm  |
| DUT Tune Voltage<br>Voltage Tune Range<br>Max Current   | For Vcc control of some DUTs.<br>-10V to +12V<br>5mA  |
| DUT Power Supply<br>Voltage Supply Range<br>Maximum Current                                   | Integrated power supply.<br>0V to +12V<br>250mA   |
| LO1/LO2 Input(s)<br>Frequency Range (standard)<br>Power Level Range<br>Input Damage Level     | Connect to LO1/LO2 Output(s) for standard operation.<br>10MHz to 6GHz<br>+7dBm to +12dBm<br>> +22dBm  |
| LO1/LO2 Output(s)<br>Frequency Range (standard)<br>Power Level Range                          | CW sources for residual measurements. Connect to LO1/LO2 Input(s) for standard operation.<br>10MHz to 6GHz (0.001Hz step size)<br>0dBm to +10dBm (0.01dB step size) |
| LO1/LO2 Tune Voltage<br>Voltage Tune Range<br>Max Current<br>Tuning Sensitivity               | For independent Vcc control of external LO sources during External LO Mode of operation.<br>-10V to +12V<br>5mA<br>TBD  |
| DUT ch1/ch2 Input(s)<br>Frequency Range (standard)<br>Power Level Range<br>Input Damage Level | Allows bypass of DUT power splitter for direct access to the phase detector of each channel.<br>10MHz to 6GHz<br>0dBm to +14dBm<br>> +16dBm                         |
| ch1/ch2 Splitter Bypass Output(s)   | Connect jumper cable to ch1/ch2 DUT Input(s) for standard operation.  |
| ch1/ch2 Baseband Input(s)<br>Frequency Range<br>Power Level Range<br>Input Damage Level       | DC to 40MHz<br>± 1Vdc<br>± 2Vdc, or 50mA (whichever is greater)   |

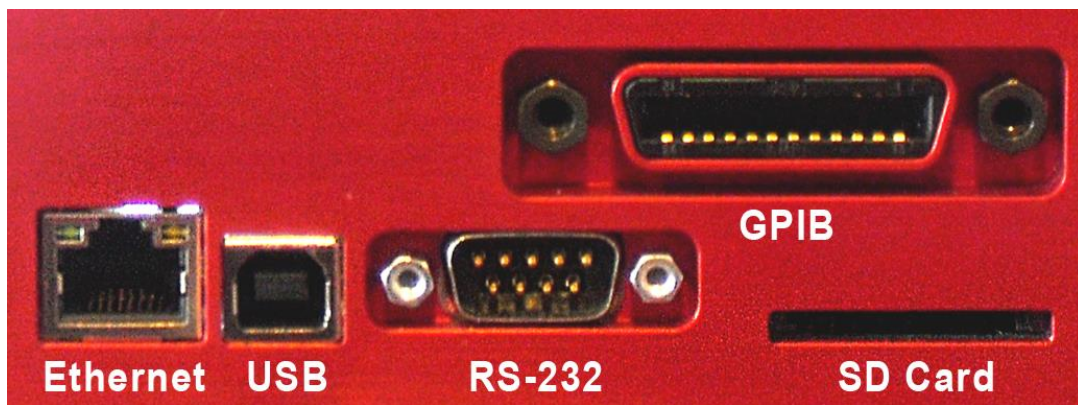
CONFIGURATION

**CONFIGURATION (continued)**

**REAR PANEL**

| DESCRIPTION   | SPECIFICATION  |
|---|--|
| <b>Reference Output Port</b><br>Connector Type<br>Output Frequency<br>Output Level<br>Output Waveform | SMA, 50ohm<br>10MHz $\pm$ 10Hz<br>+5dBm $\pm$ 2dBm<br>Sinusoid   |
| <b>10MHz Reference Input Port</b><br>Connector Type<br>Input Frequency<br>Input Level                 | ONLY FOR FREQUENCY COUNTERS - DOES NOT AFFECT MEASUREMENT SENSITIVITY<br>SMA, 50ohm<br>10MHz $\pm$ 10Hz<br>0dBm to +10dBm (Sinusoid or Square) |
| <b>AC Power Input</b><br>Connector Type<br>AC Input Rating  | International Power Supply<br>IEC 320-C13<br>90-260V <sub>AC</sub> , 50-60Hz. Specify country at time of order for proper power cord.          |
| <b>Data I/O Interface</b><br>Connectivity<br>Storage  | USB B-Type (virtual comm. port), Ethernet, RS-232, GPIB<br>SD Card Reader  |

**CONFIGURATION**

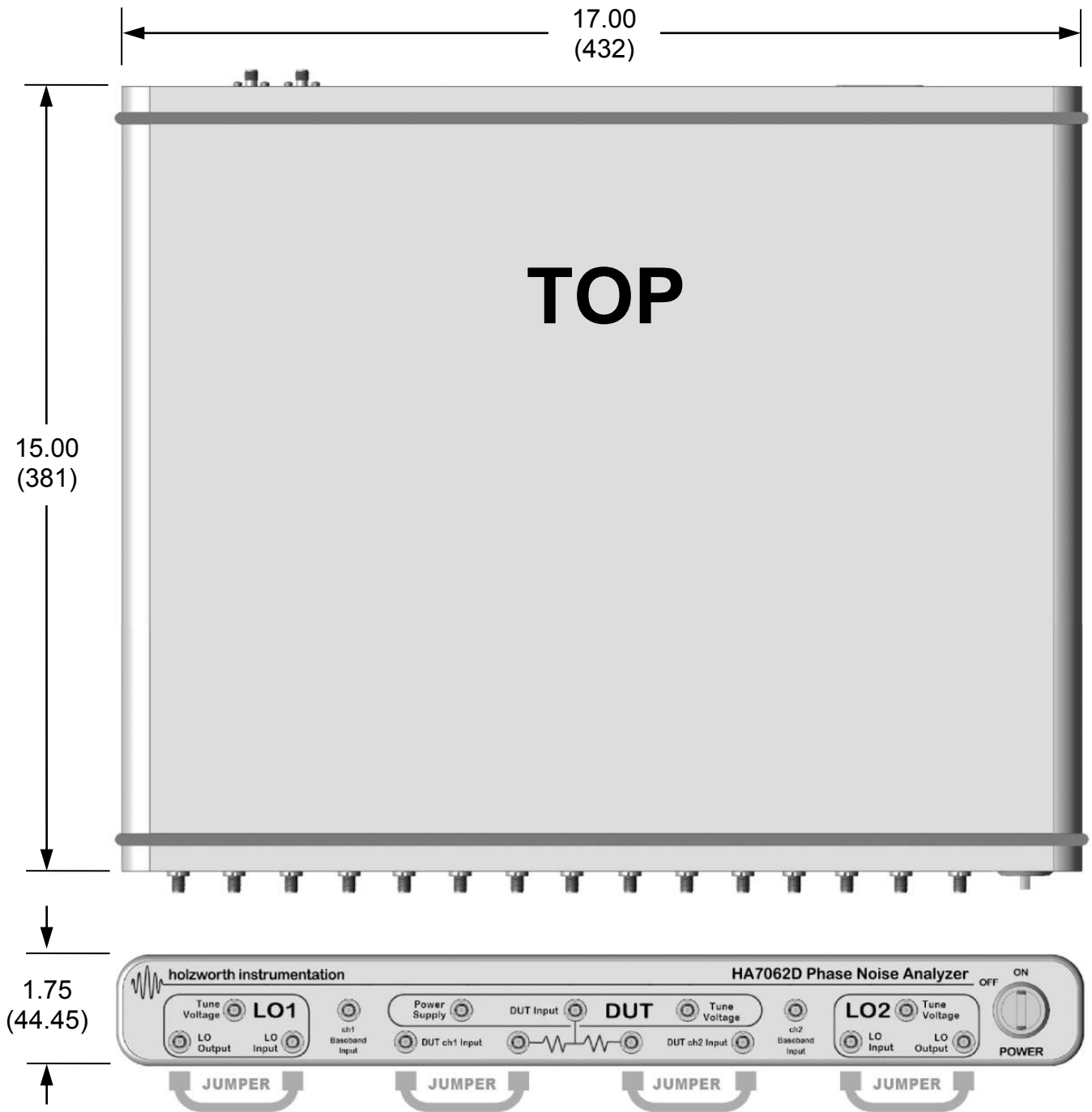


**Figure 8: HA7062C Communication Ports**

**CONFIGURATION (continued)**

**MECHANICAL DIMENSIONS**

The HA7062D has a 1U high, rack mountable chassis form factor. The fan-less design was adopted to eliminate the potential for microphonics. A universal rack mount bracket kit is an available accessory (Part No.: RACK-1U or RACK2-1U). Mechanical dimensions are listed in inches (and millimeters).



CONFIGURATION

### CONFIGURATION (continued)

#### AC POWER SUPPLY

The HA7062D utilizes an ultra-clean, international, switching power supply. Units ship with a country specific, AC supply cable. Please specify country of end use at the time of purchase.



CONFIGURATION

#### ENVIRONMENTAL

| DESCRIPTION  | SPECIFICATION (by design)   |
|--|---|
| <b>Operating Environment</b><br>Temperature<br>Humidity<br>Altitude<br>Vibration   | +10C to +40C<br>RH 20% to 80% at wet bulb temp. <29C (non-condensing)<br>0 to 2,000m (0 to 6,561 feet)<br>0.21 G-rms maximum, 5Hz to 500Hz  |
| <b>Storage (Non-Operating)</b><br>Temperature<br>Humidity<br>Altitude<br>Vibration | -10C to + 60C<br>RH 20% to 80% at wet bulb temp. <40C (non-condensing)<br>0 to 4,572m (0 to 15,000 feet)<br>0.5 G-rms maximum, 5Hz to 500Hz |

### CONFIGURATION (continued)

#### OPTIONS & ACCESSORIES

Holzworth offers options and accessories to optimize the analyzer for an intended application. Specify all required options and/or accessories when requesting a quotation or placing a purchase order.

| PART No. | DESCRIPTION  | CLASSIFICATION |
|----------|--|----------------|
| OPT-CC40 | 10MHz - 40GHz Cross Correlation Measurements   | ACCESSORY      |
| HX5100-x | Electronic Phase Shifter PAIR, Additive Measurements, 1 Octave Bandwidth, Specify fc | ACCESSORY      |
| CASE-1U  | Ruggedized Carrying Case with TSA security lock                                      | ACCESSORY      |
| RACK-1U  | 19" Rack mount bracket kit for HA7000 Series. 90 degree rear bracket.                | ACCESSORY      |
| RACK2-1U | 19" Rack mount bracket kit for HA7000 Series. Straight rear bracket.                 | ACCESSORY      |

#### INCLUDED HARDWARE AND CERTIFICATIONS

Each standard product delivery includes specific, standard hardware and certifications.

| TYPE        | DESCRIPTION  | COMMENTS       |
|-------------|--|----------------|
| HARDWARE    | <b>HA7062D PHASE NOISE ANALYZER</b>  | DELIVERABLE    |
| HARDWARE    | <b>AC Power Cord (7ft/2.1m). Specify country of end use.</b>                                       | DELIVERABLE    |
| HARDWARE    | <b>Ethernet Cable (10ft/3m)</b>  | DELIVERABLE    |
| HARDWARE    | <b>USB Cable (6ft/1.8m)</b>  | DELIVERABLE    |
| CERTIFICATE | <b>ANSI z540.1 CALIBRATION CERTIFICATE (0.1Hz - 40Mhz)</b>   | DELIVERABLE    |
| WARRANTY    | <b>3 YEAR MANUFACTURER'S WARRANTY</b>  | NON-APPLICABLE |
| CERTIFICATE | <b>CE COMPLIANCE CERTIFICATE</b><br><i>DIRECTIVE: 2004/108/EC, TEST STANDARD: EN 61326-1: 2006</i> | WEB DOWNLOAD   |
| CERTIFICATE | <b>RoHS COMPLIANCE CERTIFICATE</b><br><i>DIRECTIVE: 2002/95/EC</i>                                 | WEB DOWNLOAD   |
| CERTIFICATE | <b>WEEE COMPLIANCE STATEMENT</b><br><i>DIRECTIVE: 2002/96/EC</i>                                   | WEB DOWNLOAD   |

CONFIGURATION

### HA7062D OPERATION

All data processing is performed internally on the HA7062D. Measurement settings can be changed using serial commands sent to the HA7062D via any of the included communication options (see *CONFIGURATION* on page 12). Measurement results can be read back directly from the instrument, eliminating the use of the GUI software. This capability provides unparalleled operational flexibility, ideal for ATE applications.

Purchase of an HA7062D includes access to the C++ based GUI for hardware operation and viewing/saving data. All software upgrades and functionality additions are freely available for the life of the instrument at no additional cost to the user.

### HA7062D SOFTWARE

The HA7062D GUI offers an extremely user-friendly means to utilize the full functionality of the HA7062D on any Windows-based PC. Absolute, Additive, Jitter, AM Noise, and more can be performed using the intuitive software GUI. Refer to the software menu summaries on page 17.



SOFTWARE

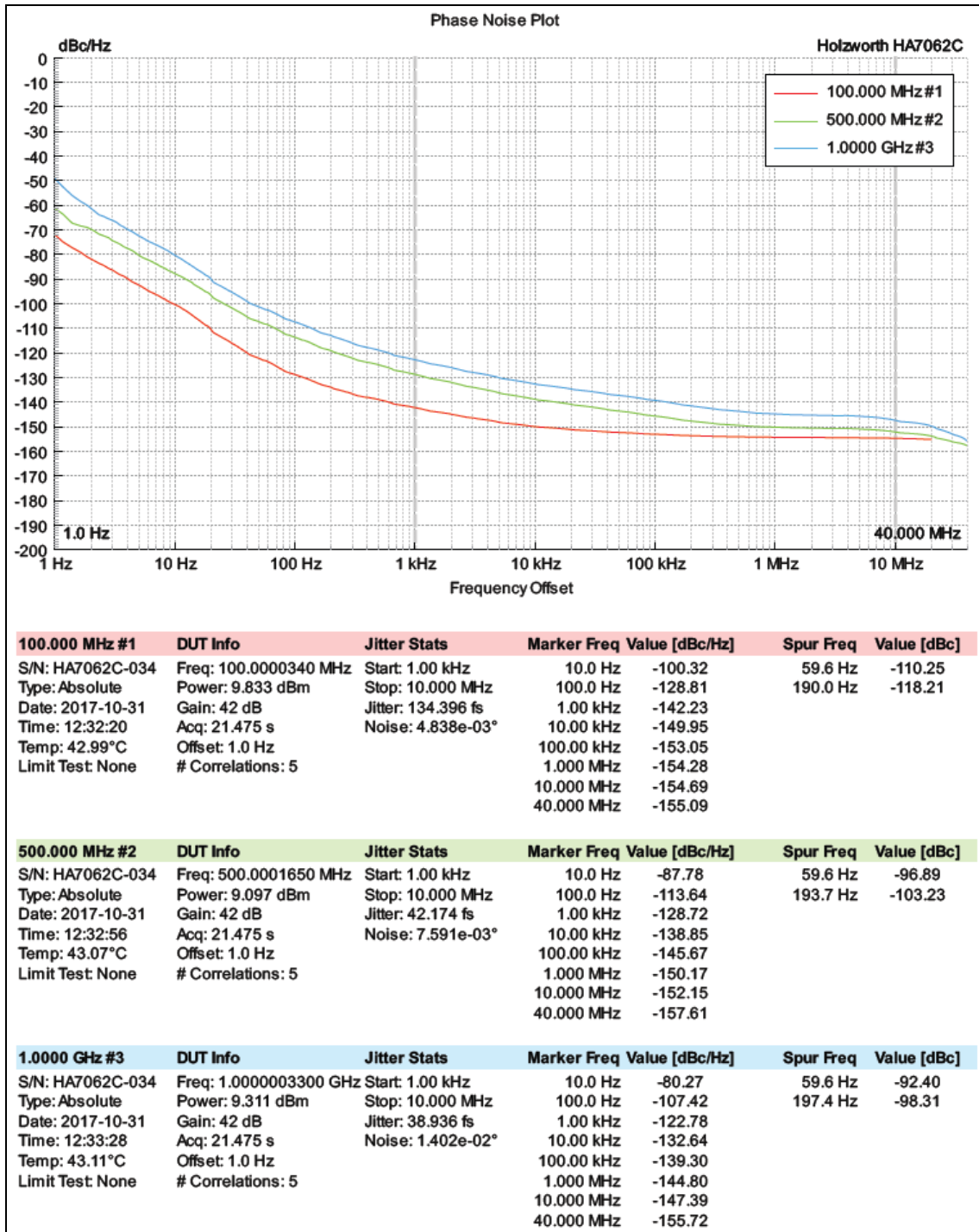
**HA7062C SOFTWARE (continued)**

The software menus indicated on page 16 are summarized as follows:

1. **File:** Save, load, export, import data; and generate reports. The report generator captures the current plot and any measurement statistics (see page 18).  
**Tools:** Quick access to the Tune Voltage outputs on the analyzer and displays input frequency and power for either LO1, LO2, or the DUT port.  
**System:** Create instrument setting presets (saving time for commonly used measurement setups), view/save measurement debug files, and manually perform firmware updates.
2. **Acquire / +:** The 'Acquire' button initiates/stops a phase noise measurement. When the '+' button is depressed, selecting 'Acquire' will overlay a new measurement to the existing data captured in the plot area with each new acquisition.
3. **Devices:** 'Devices' allows the user to view any HA7062D analyzer directly connected to the PC (USB or Ethernet) or over a LAN connection (Ethernet only) for multi-device control. Available devices are selected by part number/serial number.
4. **Measurement:** Make changes to measurement type, offset range, jitter parameters, number of correlations, *etc.*
5. **Inputs:** Used to verify DUT/LO power and frequency, calibrate and make adjustments for both internal and external LO sources.
6. **Outputs:** Provides tune control for the DUT Power Supply, DUT Tune Voltage, External LO Tune range and Internal LO power levels.
7. **Trace/Calcs:** Access to smoothing and spur removal functions to a data modify data markers. This sub-menu also contains the spurious analysis toolbox.
8. **Limits:** Apply test limit lines to the plot area for indicating pass/fail conditions.
9. **Markers:** Adjust the number of data markers, their locations and behavior.
10. **Display:** Provides access to plot data plot area modifications. Used to edit the x/y axis ranges, plot title, axis titles, trace names, plot export options, *etc.*
11. **Console:** The Console displays a log of instrument/measurement activity while also allowing the user to send commands directly to the instrument.
12. **Data Plot Area:** Displays acquired data: PM, AM, baseband, spurious, *etc.*
13. **Status Indicator:** The Holzworth logo shockwave doubles as a status bar/indicator while measurements are in progress. A measurement countdown timer is also displayed above the shockwave.
14. **Measurement Statistics:** Displays statistics of an active measurement or currently of a specifically selected data trace.

### HA7062C SOFTWARE REPORT GENERATION

The automated report generation tool is a convenient feature for quickly generating a preformatted report that captures all traces and applicable data that is currently being displayed by the GUI. Each data trace actively contained in the plot area will be included in the report and color coordinated with its corresponding data.



SOFTWARE



# HA7062D

## PHASE NOISE ANALYZER

### 3 YEAR WARRANTY

All Holzworth phase noise analyzer products come with a standard 3 year 100% product warranty covering manufacturing defects and workmanship. All product repairs and maintenance must be performed by Holzworth Instrumentation. Holzworth reserves the right to invalidate the warranty for any product that has been tampered with or used improperly. Refer to Holzworth Terms & Conditions of Sales for more details.

Holzworth products are proudly designed and manufactured in the USA.



### CONTACT INFORMATION

Contact Holzworth directly for a product quotation, a product demonstration, or for technical inquiries.

**Holzworth Instrumentation Sales Support**  
Phone: +1.303.325.3473 (option 1)  
Email: sales@holzworth.com

**Holzworth Instrumentation Technical Support**  
Phone: +1.303.325.3473 (option 2)  
Email: support@holzworth.com

[www.HOLZWORTH.com](http://www.HOLZWORTH.com)

