

Electrical Safety Analyzer

MODEL 19032/19032-P

Key Features :

- AC/DC/IR/GB/LC five instruments in one
- Function test up to 20A
- Programmable voltage output and limit value
- OSC open/short check
- Flashover detection
- Human protection circuit
- Multi-scan device support dynamic leakage current test
- Standard RS232 interface
- Optional GPIB interface
- Large LCD panel
- Front panel lockout function
- Support PC software
- UL/TUV/CE

Key Features 19032-P :

- 500VA output
- Floating output , compliance with EN50191
- USB interface, compatible with USB TMC
- GFI human body protection circuit
- CE certification (only)



ELECTRICAL SAFETY ANALYZER MODEL 19032/19032-P

General Electrical Safety Testing Solution

Electrical safety testing is one of the major item in the electrical product quality tests. All electrical products consisting of adapter, SMPS, charger, house appliance, information technology product and video product are required to perform electrical safety tests.

The 19032 series combines Hi-Pot, IR, GB, LC/ALC/DLC and Dynamic Function Test. That can save 50% of production line space without purchasing several Hi-Pot testers , 19032 is able to increase efficiency of electrical safety test during manufacturing and reduce the risk on testing.

Open/Short Check (OSC)

Patent No. : 254135

All manufacturers have to solve the problems of error connections and unconnected test cables caused by the production line testers. Chroma 19032 equip with the up-to-date open/short check function (OSC) for product testing. It can free the tests from such problem.

Twinport™ Function

USA Patent No.: US6504381

The key factor affecting the efficiency of manufacturing is the efficiency for electrical safety test. Twinport function can lower the time for safety test, and safety workstation will no longer be a bottleneck in production line.

Product Application

The 19032 can be applied to versatile tests of electrical products which include quality assurance sampling inspection test, manufacturing test and development validation.

- Power cord
- Adapter, SMPS
- House appliance
- Information technology product
- Medical equipment
- Lab/testing equipment
- EMI FILTER

EN50191 Floating Output Function

The leakage current of any ground terminal should be lower than 3.5mA when operating Floating output function. Therefore, the operator who near to potential ground terminal can avoid electrical hazard.



Chroma



TWINPORT™ HIPOT & GROUND BOND TEST FUNCTIONS (USA PATENT NO.: US6504381)

The 19032 electrical safety tester has Twinport™ Technology. This patent and unique feature are allow to test Hi-pot and ground bond simultaneously. It can reduce half of the time on testing;so it is ideal for production test.

Conventional Safety Analyzer	Ground Bond	Hipot
19032	Ground Bond Hipot	
	2 Sec.	2 Sec.

FLASHOVER DETECTION

The 19032 has Flashover Detection as other Chroma safety test series. Flashover is electricity transient or non-sequential discharge generated by the inner or surface of insulation component which cause DUTs to lose original insulation feature,generated carbonation electrically conductive path and damages the product . Test voltage or shift rate of leakage current is required. As flashover cannot be detected by leakage current, Flashover Detection is one of inevitable inspection items in HV test.

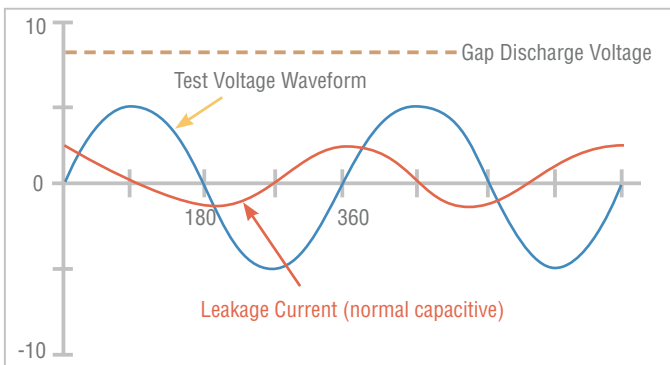

Figure 1 : Normal Leakage Current Waveform

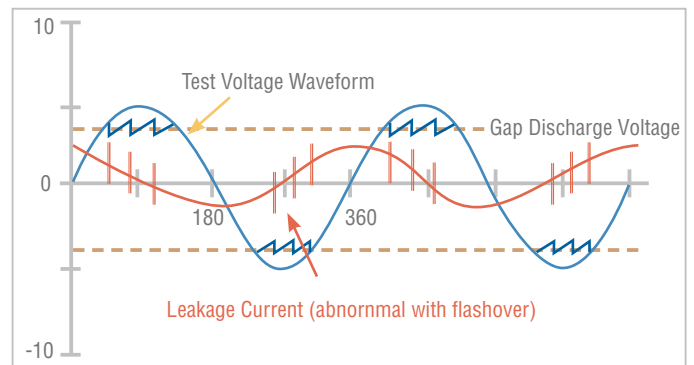

Figure 2 : Leakage Current Waveform when flashover occurred

OPEN / SHORT CHECK (OSC) (PATENT 254135)

OSC function is used to check if the connection is open (bad contact) or short (DUT short) during the test procedure. When circuit opened during the test, NG product will be judged as good product. When short occurred during the test, screening earlier can reduce the damage on equipment .

Generally speaking, the DUT has capacitive load (C_x) from tens of pF to several uF in normal state. A micro capacitance will occur on an open circuit interface, once the connection is interrupted (as C_c in figure 2). In general, the capacitance is lower than 10pF ; thus the total capacitance is far lower than the normal product. The capacitance is far higher than normal when the DUT short or close to short. Therefore, users can judge the short problem by using the high/low limit value of capacitance change.

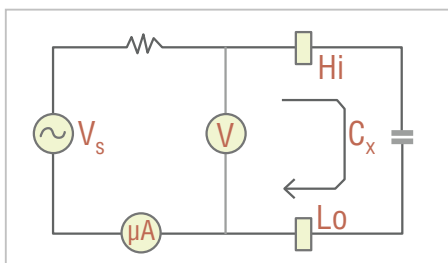

Figure 1 : Normal Connection

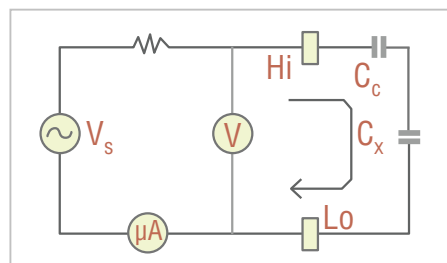

Figure 2 : Connection Open

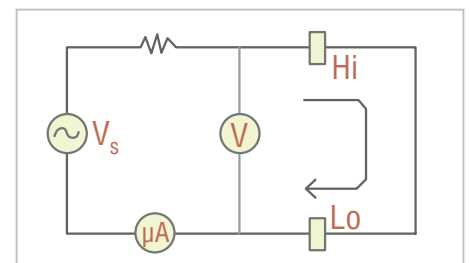

Figure 3 : Connection Short

CAPABILITY OF CONTROLLING CHROMA AC SOURCE (6400 / 61600 / 61500 SERIES)

The manufacturers apply Chroma AC Source as the power supply to increase the input voltage stability for dynamic leakage current test. The 19032 uses RS232 interface to control the AC Source related models that make the dynamic leakage current test more convenient.



GFI HUMAN PROTECTION (19032-P)

The ultimate purpose of safety testing is to protect users from electric hazard. The 19032-P also has GFI function to protect the operator. GFI function can cut off the power output immediately while human body is suffering electric shock. GFI function detects the current from Earth GND (Ioperator) and LOW terminal (Idevice). The voltage output will be cut off if the current is over 0.5mA.

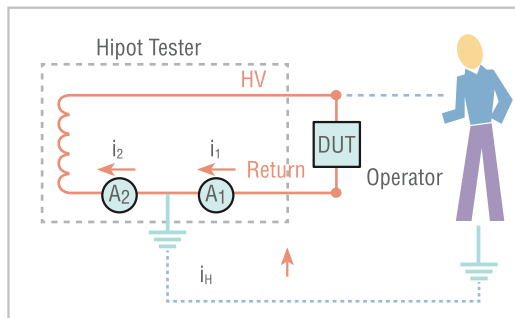

FLOATING CIRCUIT FUNCTION (19032-P)

For the operator to use the Safety Test Instrument more safely, Chroma invented a floating circuit based on leading technology. Under floating status, the grounding leakage current will not exceed 3.5mA no matter what the withstand voltage. If the person touches any terminal, it complies with EN50191 for outputting to ground terminal within current limit and for protecting the operator from electrical injury.

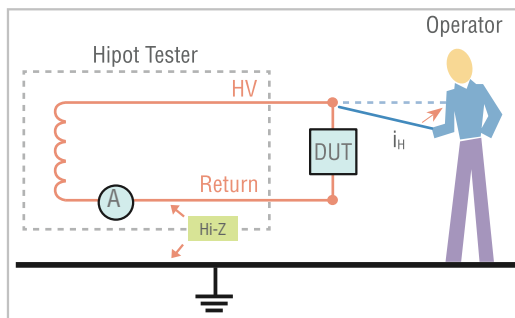

SUPPORT TOUCH CURRENT / LEAKAGE CURRENT TEST

The current that flows through insulation resistance after being brimmed is called leakage current. When leakage current flows through a human body, it can cause electric damage. The leakage current is tested under operating state. A human body RC network is added in leakage current test; it can simulate the value of leakage current in real conditions.

The leakage current has different testing modes and standards in accordance with different safety standards and test points. The most often seen current tests are Earth Leakage Current, Patient Leakage Current, and Patient Slave Leakage Current.

The 19032 is used with different dynamic leakage current modules and human body simulation equivalent circuits for the requirements of various safety modules. It can be applied to Electrical Safety Testing for Household Appliances, Video Products, Medical Equipment, and etc.

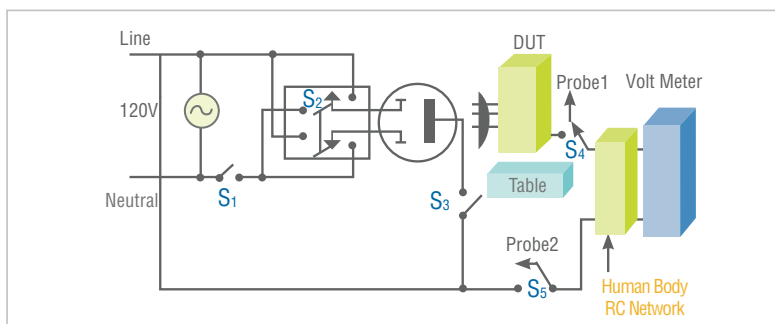

UL 544 NON PATIENT	UL 544 PATIENT CARE	UL 1563 IEC 60335-1 IEC 601-1	UL 2601-1 IEC 60601-1	UL 1950 UL 3101-1 IEC 60950 IEC 1010 IEC 60990 / Fig4 Reaction	UL 1950 U1 IEC 60990 Fig3 Unweighted

500VA HIPOT TEST (19032-P)

The high limit of Hipot test is currently often from 5 to 10mA. However, there are still a few DUTs such as Safety Integrated Analyzer of EMI Filter or large-sized motor that require massive power. The 19032-P enhances the power of 19032 largely to equip the capabilities of outputting and measuring AC 100mA/DC 20mA.

To integrate the high charge current with other safety tests as any integrated analyzer for the users to use higher leakage current or large-sized electrical safety equipment. This brings the best efficiency to production line and quality assurance.

The design of 500VA also complies with the requirement of IEC/UL output power to add the selection function of "no protection for trip circuit under short current 200mA and 100mA".



SAFETY TEST OF INFORMATION TECHNOLOGY PRODUCT (IEC 60950)

In digital time, information technology is so close to our life. Desktop, notebook, LCD monitor, UPS, printer and projector are the products that human may use at any time. To ensure the safety, all products should do electrical safety test. The 19032 offers all functions of safety tests and Normal/Reverse as well as Single Fault switch function (LC Test) to reduce the load of manufacturing personnel.

Besides, the output floating of Telecommunication Network in IEC 60950 to perform dynamic leakage current test is required. The equivalent stray capacitance will also be generated on isolated transformer even it is floating circuit. The stray capacitance results in leakage current, electrical damage to users. The 19032 along with 6000-05 /07/08 leakage current scanner have P1/P2 measurement function which is able to measure dynamic leakage current on output terminal. It is the best solution for testing information technology products.

Main Test Item

- Open Short Check
- Ground Bond
- AC/DC Hipot Test
- Earth Leakage Current Test
- Output Leakage Current Test

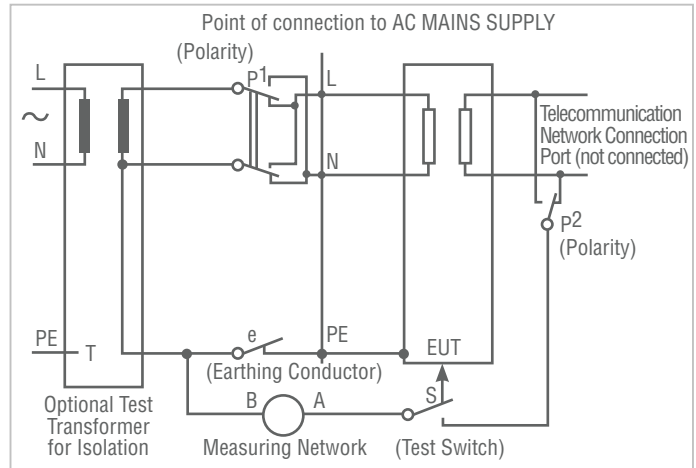
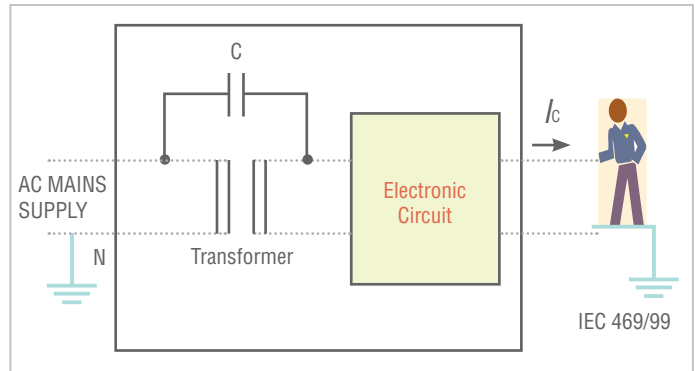

LIGHTING INDUSTRY AND LED RELATED ELECTRICAL SAFETY TEST

LED on the lighting industry is widespread gradually in the daily life. Each LED and power product need to be tested for withstand voltage, insulation, grounding resistance and leakage current for protection from personal electric shock hazard.

Test item	Test Condition	
Leakage Current Test	IEC 60990, Measure network Figure 4, Configuration Figure 6	
Withstanding Voltage Test	Working voltage < DC42V	WV Test Voltage 500V
	Working voltage ≥ DC42V	WV Test Voltage (2U+1000)V
Ground Bonding Test	Current from AC source of 25A passed for 1min between earthing terminal and each of the accessible metal parts(IEC 61347-1)	

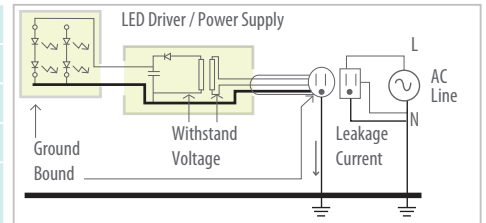

POWER SUPPLIES, ADAPTER AND CHARGER SAFETY TESTING

Power supply of electronic products including SMPS, Adapter and charger need to perform electrical safety test. According to various power design methods and test conditions, the 19032 offers programmable edit and solution to let you complete all tests at one time.

A lot of designs of power product, the insulation capability of input terminal (Primary) to output terminal (Secondary) is required to protect the damage inside component. Thus, the output terminal of Floating needs to perform Hipot test. The 19032 provides isolation test point with high voltage which allows you not to change the fixture or cable manually but perform P-S Hipot test directly after P-G Hipot test.

Test item	Open & Short (OSC)	Ground Bonding	Withstanding voltage from primary to Ground	Withstanding voltage from primary to Secondary	Leakage Current
Power supply sources					
Three-wire power supply class 1 (Secondary Floating)	V	V	V	V	V
Three-wire power supply class 1	V	V	V	-	V
Two-wire power supply class 2	V	-	-	V	V

Moreover, if there is danger to touch output terminal (Secondary), dynamic leakage current test also needs to be performed.

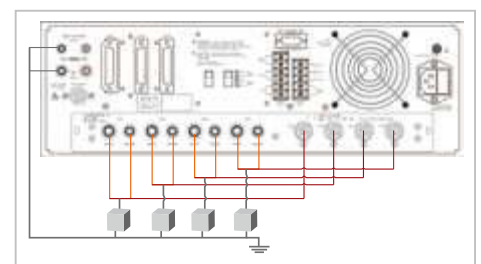

Chroma19032 with 4HV/4GC Scanner

SAFETY TEST OF VIDEO PRODUCT (IEC 60065)

Video products are inclusive of DVD recorder, LCD TV, audio amplifier, stereo and etc. These products have mass power output with separate safety standards. The main circuit design of mass power is signal output terminal beside temperature increasing and heat dissipation of electronic component. Open voltage of some video products is over 35Vac peak or 60Vdc peak that performs U1 dynamic leakage current test is required. U1 measurement circuit is added to the 19032 and P1/P2 measurement point is provided that to comply with the requirement of safety standard test.

Main Test Item

- Open Short Check
- Ground Bond
- AC/DC Hipot Test
- Earth Leakage Current Test
- Output LC Test

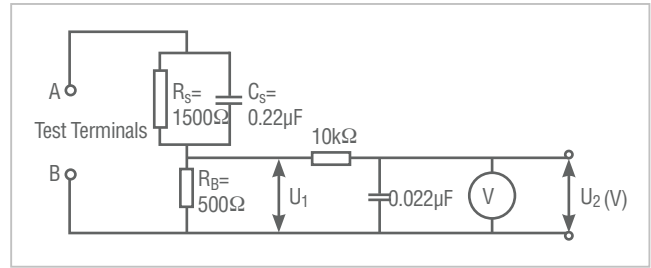

SAFETY TEST OF HOUSEHOLD APPLIANCE (IEC 60335)

Household appliances consist of oven, refrigerator, television, juicer and coffee machine that human may contact at any time. To ensure the safety of users, all products should do electrical safety tests. Except for basic Hipot test, dynamic leakage current has various test regulations by different ground modes and operation methods. The regulations are as the table shown below.

Main Test Item

- Open Short Check
- Ground Bond
- AC/DC Hipot Test
- Earth Leakage Current Test

for Class II appliances	0.25mA
for Class 0, Class 01 and Class III appliances	0.5mA
for Portable Class appliances	0.75mA
for Stationary Class Moto-Operated appliances	3.5mA
for Stationary Class Heating appliances	0.75mA or 0.75mA per kW rated power input of the appliances with a maximum of 5 mA, whichever is higher

SAFETY TEST OF MEDICAL EQUIPMENT (IEC 60601)

19032 + 6000-07 is a solution for electrical safety and function test of medical equipment. The safety standard of medical equipment is very strict. Since the medical equipment contacts the body of doctor and patient oftenly, it makes various electrical safety tests that cannot be ignored especially the leakage current test which has already become the most important test in electrical safety test.

The safety standard of medical equipment has various of leakage current tests. In addition, normal / reverse / single fault normal / single fault reverse four powers and earth switch, made the safety test difficulty and complexity further. The basic measuring circuit for the enclosure leakage current is as the figure. Moreover, it shows here measurement Type BF and CF is a special requirement for medical equipment. DC leakage current should be isolated separately and limited within 50uA limited which mentioned in medical safety standard. The function has already been added to the 6000-08 LC scanner. Chroma 19032 + 6000-07/08 offer programmable editing and software support, That all you to test medical product without missing procedure so it saves the test data directly to provide you the best test solution.

Main Test Item

- Open Short Check
- Ground Bond
- AC/DC Hipot Test
- Earth Leakage Current Test
- Enclosure LC
- Patient LC
- Patient Auxiliary LC

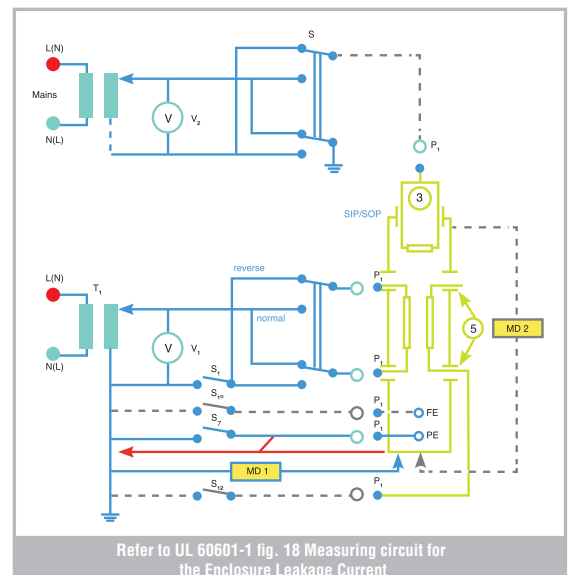

ELECTRIC VEHICLE SAFETY TEST

Automotive industry has already converted from internal combustion engine power to electric power. Because the voltage of electric vehicle will be maximum up to 600V when operating, its safety issue. To avoiding electrical injury is also important Chroma 19032 is the best solution for electrical safety tests of connecting wire and connector of electric vehicle, adapter, battery, charging station system.

Test Item

- Withstand voltage test: Various insulation terminals, primary and uncharged metal, withstand voltage between primary and secondary.
- Leakage current: All metallic parts can be touched on the system required to test earth leakage current during dynamic operation.
- Ground test: Ground protection connection should use 25A/60Hz current to test resistance, it cannot higher than 100mΩ.

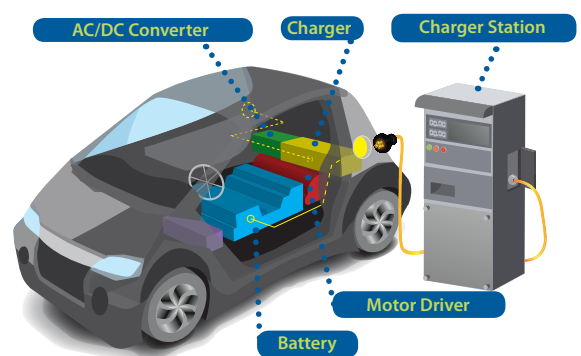

LEAKAGE CURRENT SCANNER

Different safety standards have various leakage current requirements which include test method and max. current output. Chroma 19032 is able to combine different scanners for safety needs. As the table list below.



Option			HIPOT		GB			LC				
No	Name	General Application	Ports	Voltage Max	Ports	Current Max	Power Output	LC Probe	Earth LC	Touch LC	Patient LC	Patient Aux LC
A190301	9030A (Ext.)	customized	8 ports	5KVvac 6KVdc	-	-	-	-	-	-	-	-
A190302	6000-01	customized	5 ports		3 ports	30A	-	-	-	-	-	-
A190303	6000-02	customized	3 ports		5 ports	30A	-	-	-	-	-	-
A190304	6000-03	customized	8 ports		-	-	-	-	-	-	-	-
A190305	6000-04	IT product House appliance	L+N to E P to S		-	-	300V/10A	-	●	-	-	-
A190306	6000-05	Lab/TN			-	-	300V/10A	P1&P2	●	●	●	●
A190308	6000-07	Medical equipment			-	-	300V/20A	P1&P2	●	●	●	●
A190350	6000-08*	Special Medical Audio & Video			-	-	300V/20A	P1&P2	●	●	●	●
A190353	6000-11	Customized			4 ports	4 ports	40A	-	-	-	-	-

OPTIONAL FIXTURE

Chroma provides related optional test optional fixtures for different test requirements .

- **Isolation Transformer** : The isolation transformer is an auxiliary and the DUT floating is connected while performing leakage current test.The above are described in the safety standard.
- **Dummy Load** : The main function of the fixture is to confirm the normality of the instrument before daily power on.
- **Bar-code Scanner** : It can connect with 19032 directly.
- **Current Transformer** : It is able to rise ground bond test to 40A or 60A.
- **Universal Corded Product Adapter** : Using this adapter can perform test directly for various types of plug in different countries.



Isolation Transformer



Dummy Load



Current Transformer



Universal Corded Product Adapter

EST SOFTWARE

EST software can control Chroma 19032 to perform electrical safety integrated test. Having EST software, you can save the test procedure and data directly as well as converting them to EXCEL file for the convenience of management and statistical analysis.

- Program edit and GO/NG control
- Data bank
- Report function
- Statistical analysis function
- Authority management function

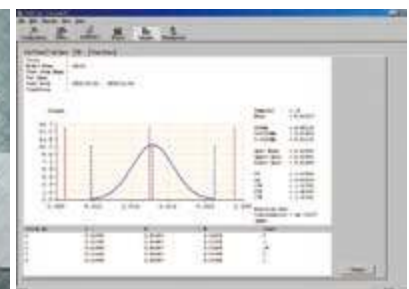

PANEL DESCRIPTION

19032

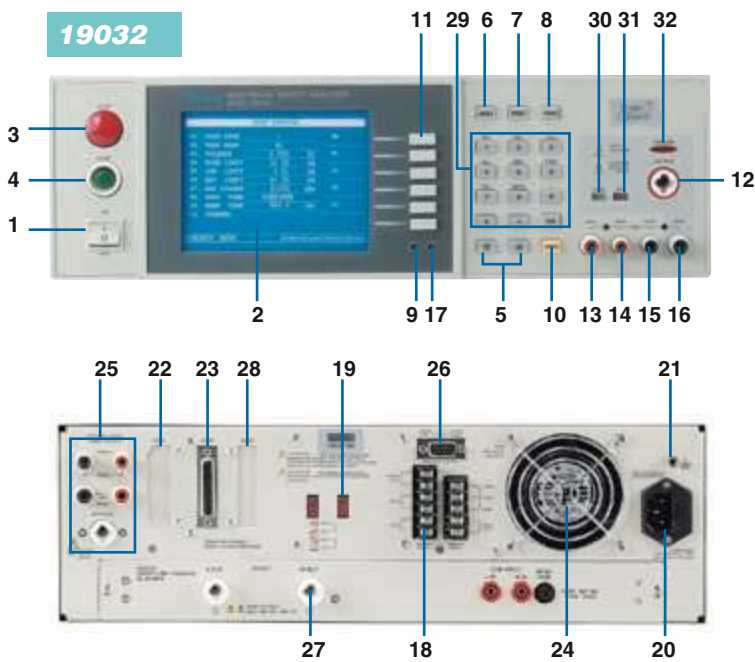

19032-P

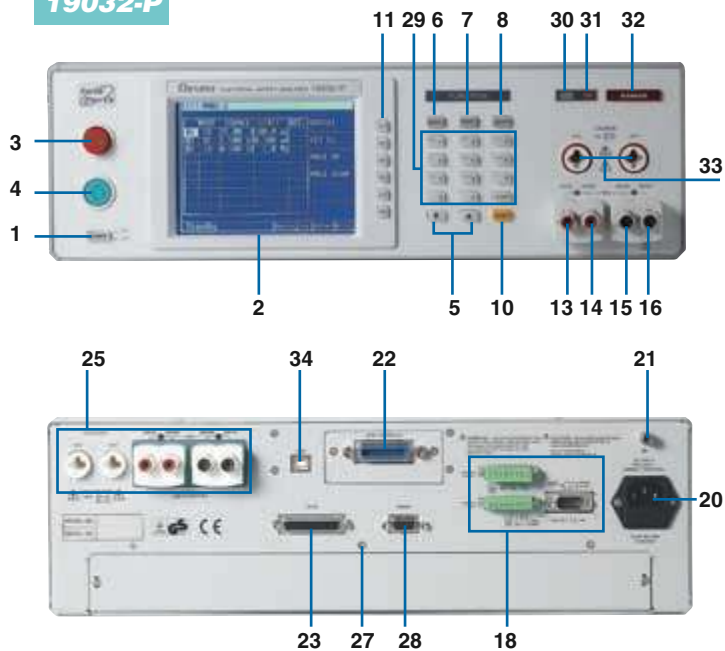

1. Power Switch
2. LCD Display
3. Stop Key
4. Start Key
5. Cursor Keys
6. TEST Key
7. PRINT Key
8. SYSTEM Key
9. Cal-Enable (19032)
10. DATA Entry Key
11. Function Key
12. HV Output
13. DRIVE+
14. SENSE+
15. SENSE-
16. DRIVE-
17. Update Enable (19032)
18. Remote I/O
19. Line Voltage Selector
20. Power Cord Receptacle
21. GND Terminal
22. GPIB Interface
23. SCAN Interface
24. Fan
25. Rear Panel Output
26. I/O Control (9 pin)
27. Scan Box
28. RS232 Interface
29. Data Entry Keys/Program Keys
30. PASS Indicator
31. FAIL Indicator
32. DANGER Indicator
33. Floating Output (19032-P)
34. USB Interface (19032-P)

SPECIFICATIONS

Model	19032	19032-P
Mode	AC/DC/IR/GB/LC	
Withstanding Voltage Test		
Output Voltage	DC:0.05 ~ 6kV , AC : 0.05 ~ 5kV	
Load Regulation	±(1% reading +0.1% range)	±(2% reading +0.1% range)
Voltage Resolution	2V	
Voltage Accuracy	±(1% reading +0.1% range)	±(2% reading +0.1% range)
Cutoff Current	DC : 20mA , AC : 40mA	DC : 20mA , AC : 100mA
Current Resolution	0.1 µA DC ; 1µA AC	
Current Accuracy	±(1% reading +0.1% range)	±(2% reading +0.5% range)
Output Frequency	50Hz / 60Hz	
Test Time	0.3 ~ 999 sec , continue	
Ramp Time	0.1 ~ 99.9 sec, Off	
Fall Time	0.1 ~ 99.9 sec, Off	
Waveform	Sine wave	
Insulation Resistance Test		
Output Voltage	DC : 0.05 ~ 1kV	
Voltage Resolution	2V	
Voltage Accuracy	±(2% of reading +0.5% of range)	
IR Range	1MΩ ~ 50GΩ	
Resistance Resolution	0.1MΩ	
Resistance Accuracy	5% typical	
Ground Bond Test		
Output Current	AC : 1 ~ 30A	AC : 3 ~ 40A
Current Accuracy	±(1% of reading +0.2% of range)	
GR Range	10mΩ ~ 510mΩ	
Resistance Resolution	0.1mΩ	
Resistance Accuracy	± (1% of reading + 0.1% of full scale)	
Test Method	4 wires	
Flashover Detection		
Setting Mode	Programmable setting	
Detection Current	AC : 20mA, DC : 10mA	
Secure Protection Function		
Ground Fault Interrupt	-	0.5mA ±0.25mA AC
Floating Output	-	3.5mA, front output only
Panel Operation Lock	Present password	
Interlock	YES	
GO/NG Judgment Window		
Indication,Alarm	GO : Short sound,Green LED ; NG : Long sound, Red LED	
Data Hold	Least tests data memories	
Memory Storage	50 setups with up to 100 groups recall	
Interface		
9pin D-sub I/O control / RS232 / GPIB (Optional) / USB TMC (19032-P)		
General		
Operation Environment	Temperature : 0°C ~ 40°C, Humidity : ± 80 % RH	
Power Consumption	No load : < 100 W With Rated load : 800 W	No load : < 100W Rated load : 1000W Maximum load : 1200W
Power Requirements	90~132Vac or 198~264Vac, 47~66Hz	
Weight	Approx. 20KG(19032) 25KG (19032-P)	

Option	6000-04 ~ 08*
Support Mode	AC/DC/IR/LC
DUT Input Power Capacity	AC : 300V / 10A / 20A max.
Short Protection	20A, 250V fuse for DUT shorted.
Measurement Mode	
Input Characteristic	DC - 1MHz Input Impedance : 1M//20pF
Measurement Mode	Normal, Reverse, Single Fault Normal, Single Fault Reverse
Measurement Devices (Five measure device)	UL 544 NP ; UL 544 P UL 1563 ; UL 60601-1, IEC60601-1; UL 3101-1, UL/IEC 60950, UL 1950-U1* ; UL 2601-U1* IEC60990
Probe Connection	Line to Ground, Line to P2, P1 to P2
HI-LO Limit	
LC HI-LO Limit	0 ~ 9.99mA, 1µA resolution
Current HI-LO Limit	0 - 19.99Amp*
VA HI-LO Limit	0 - 4400VA
VA Resolution	0.1VA

*Different option have different specification.

ORDERING INFORMATION

- 19032** : Electrical Safety Analyzer
19032-P : Electrical Safety Analyzer (500VA)
A190301 : 8HV Scanning Box
A190302 : 5HV/3GC Scanner
A190303 : 3HV/5GC Scanner
A190304 : 8HV Scanner
A190305 : Line Leakage Current Scanner (generally)
A190306 : Hipot/Line Leakage/Probe Scanner (10A)
A190307 : L-N Scanner & Leakage Current Scanner
A190308 : Hipot/Line Leakage/Probe Scanner (20A)
A190313 : 500VA Isolation Transformer
A190314 : 1000VA Isolation Transformer
A190316 : Dummy Load
A190317 : BarCode Scanner
A190508 : GPIB Interface for 19032
A190334 : Ground Bond 40A for 19032
A190337 : Ground Bond 60A for 19032
A190338 : 19001 EST Software
A190343 : 19" Rack Mount Kit for 19032
A190344 : HV Gun
A190349 : Universal Corded Product Adapter
A190350 : Hipot/Line Leakage/
 Probe Scanner (20A) 6000-08
A190353 : 4HV/4GC Scanner
A190355 : 19" Rack Mount Kit for 19032-P
A190356 : GPIB Interface for 19032-P
A190708 : ARC Verification Fixture

Developed and Manufactured by :

CHROMA ATE INC.

致茂電子股份有限公司

HEADQUARTERS

66, Hwa-Ya 1st Rd., Hwa-Ya
 Technology Park, Kuei-Shan Hsiang,
 Taoyuan Hsien 33383, Taiwan
 Tel: +886-3-327-9999
 Fax: +886-3-327-8898
 http://www.chromate.com
 E-mail: chroma@chroma.com.tw

CHINA

**CHROMA ELECTRONICS
 (SHENZHEN) CO., LTD.**
 8F, No.4, Nanyou Tian An
 Industrial Estate, Shenzhen,
 China PC: 518054
 Tel: +86-755-2664-4598
 Fax: +86-755-2641-9620

JAPAN

CHROMA JAPAN CORP.
 472, Kohoku-ku Yokohama
 city Ntsupa 223-0057 Japan
 Tel: +81-045-542-1118
 Fax: +81-045-542-1080
 http://www.chroma.co.jp

U.S.A.

CHROMA ATE INC. (U.S.A.)
 7 Chrysler Irvine, CA 92618
 Tel: +1-949-421-0355
 Fax: +1-949-421-0353
 Toll Free: +1-800-478-2026

EUROPE

CHROMA ATE EUROPE B.V.
 Morsestraat 32, 6716 AH Ede,
 The Netherlands
 Tel: +31-318-648282
 Fax: +31-318-648288