

## MODEL 19501-K

### KEY FEATURES

- Built-in AC hipot test and partial discharge (PD) detection functions
- Programmable AC hipot voltage output 0.1kVac~10kVac
- Up to 0.01 $\mu$ A~300 $\mu$ A high accuracy and high resolution current meter
- 1pC~2000pC partial discharge detection range
- High voltage contact check (HVCC) function
- Compliant with IEC60747-5-5, VDE0884 and IEC 60270 standards requirements
- Built-in IEC60747-5-5 testing methods
- Separate design for measurement and display unit
- 3 stages of voltage testing function
- PD measured results display (pC)
- PD failure count setting (1~10)
- Traditional Chinese/Simplified Chinese/English multilingual user interface
- USB storage for screen capture
- Graphical editing
- Standard LAN, USB, and RS232 remote control interface

## PARTIAL DISCHARGE TESTER MODEL 19501-K

The Chroma 19501-K Partial Discharge Tester is an instrument equipped with AC hipot test and partial discharge detection functions, providing 0.1kV~10kV of AC output, 0.01 $\mu$ A~300 $\mu$ A of leakage current, and 1pC~2000pC partial discharge detection range for measurement. It is specifically designed for testing high voltage semiconductor components and high insulation materials.

The product design of Chroma 19501-K Partial Discharge Tester is compliant to the IEC60270-1 standard in particular the partial discharge testing requirements for high voltage. It adopts narrowband measuring technology to perform the PD tests, and displays the measured results on the screen with intuitive values (pC) allowing users to clearly understand the DUT (device under test) test result.

In addition to IEC60270-1, the PD tester is also IEC60747-5-5 and VDE0884 compliant. Its embedded IEC60747-5-5 measuring methods can meet the production test requirements of optocouplers, providing a user-friendly operating interface.

When performing high voltage tests on the production line, if the DUT is poorly connected to the test cable, it could result in test failure or skipping. Thus, it is important to make sure the DUT and test cables are well connected. Chroma's unique high voltage contact check (HVCC) uses Kelvin

measurement to perform contact tests on the high insulation components with high voltage outputs, concurrently improving the test effectiveness and productivity.

When a solid insulator has air gaps or impurities mixed in the insulating layer, the high electric field strength centered on the air gaps will cause partial discharge under the rated high voltage. The continuous partial discharge will deteriorate the surrounding insulation material, affecting the long term reliability of electrical products and causing safety concerns.

Long-term damage from partial discharge to safety components used in power systems, such as optocouplers, causes the insulation of these components to fail leading to potential hazards. However, the IEC60747-5-5 standard regulates that partial discharge test in the production process (routine test) must be 100% performed, and less than 5pC discharge capacity under the maximum insulation voltage to ensure that partial discharge does not occur during the normal working environment.

The partial discharge tester provides hipot test and partial discharge detection for high insulation withstand components such as high voltage optocouplers, high voltage relays, and high voltage switches to assure quality and reliability.



**Chroma**

Partial Discharge

Partial Discharge is the local dielectric breakdown of a small portion of insulation systems, where the electric field strength exceeds the breakdown point of the insulation material; this does not bridge the space between two conductors.

The partial discharge tester applies voltage to the DUT under a certain condition to measure the apparent partial discharge (PD). Besides verifying its ability to withstand a transient high voltage (hipot test), it also verifies the insulation integrity at rated operating voltage. The partial discharge test can detect whether there are abnormal air gaps on the electrical components by applying a charge slightly above the maximum rated voltage. This also tests its long-term reliability under normal voltage conditions. Although, it is impossible to be 100% free of air gaps inside the insulation material during actual production, the IEC60747-5-5 optocoupler standard still defines that for partial discharge testing, the discharge capacity cannot exceed 5pC ( $q_{pd}=5pC$ ).

Explanation for P.D occurs

When void exist inside a solid insulator under high working voltage

1. The dielectric coefficient of air is lower than the dielectric coefficient of the insulation material causing the void electric field strength to be higher than normal insulation.
2. And, the dielectric strength of air is lower than insulation material, causes easier electrical discharge in the void.

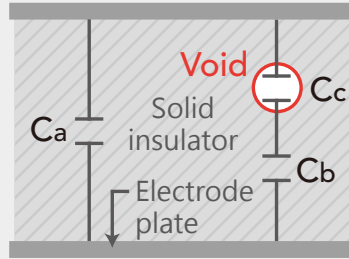

- Ca: Equivalent capacitance of the rest of the solid
- Cc: Equivalent capacitance of the air gap
- Cb: Equivalent capacitance of solid in series solid and void

Partial Discharger Calibration

When using a partial discharger to calibrate the partial discharge tester for measuring micro discharge, the signal is very small and fast. Thus, the partial discharge tester has to be accurately calibrated before shipment to ensure the high frequency signal can be measured during discharge. The IEC60270-1 high voltage test standard, which explicitly states the calibration standards and methods for partial discharge, is conformed to developing the Chroma 19501-K partial discharge tester.

The standard capacitor  $C_0$  used by the calibrator is usually a low voltage capacitor. Hence, the partial discharge tester is calibrated and de-energized when conducting the PD calibration, which means only the PD measurement circuits are calibrated. In order to make the calibration effective, the regulation states that the standard capacitance  $C_0$  used on the calibrator must be less than 0.1  $C_a$  and the pulse equivalent discharge  $q_0 = V_0 C_0$ .

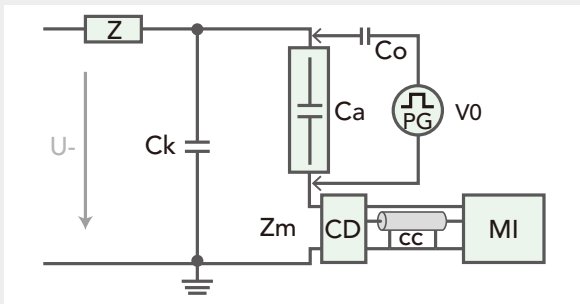

- U : High voltage supply
- Z : Filter
- Ca : Device under test
- Ck : Coupling capacitor
- Zm : Input impedance of measuring system
- CD : Coupling device
- Cc : Connecting cable
- MI : Measuring Instrument
- PG : Step voltage generator
- V0 : Step voltage

High Precision Measurement

The Chroma 19501-K is a high precision partial discharge tester equipped with 200pC and 2000pC two ranges to measure from 1pC to 2000pC, and the best resolution in range 200pC is 0.1pC. Its high accuracy measurement and intuitive display of measured results on the screen facilitate the assessment and analysis of small discharges for highly insulated objects.



## Anti-interference structure design

The partial discharge tester has a built in narrowband filter to measure small discharges; however, the equipment that is used for testing in production is different from those used in the Lab as the noise and interference include automated mechanical operation, motor movement, or high frequency radiation, etc. All of these affect the measurement and assessment of PD. Preventing and reducing the measurement circuit of the partial discharge tester from being interfered with by high-frequency radiation is a big issue to manufacturers and automation equipment suppliers.

The partial discharge occurs fast, usually in nanoseconds (nS) and at a high frequency. Because the signal is very small, the tester is easily affected by the surrounding high frequency radiation causing measurement errors. Accurately measuring the PD capacity and avoiding the interference of high frequency radiation is a technical challenge for designing the partial discharge tester.

Chroma is aware of the inevitable interference of high frequency radiation in the environment, so a separate design for the measurement and display unit is applied to the 19501-K Partial Discharge Tester. Its detachable test module can measure the DUT in the closest way to reduce the interference caused by long cables. In the meantime, the measurement circuit uses signal isolation design with an outlet probe of the shortest loop at the test end, and a copper ring to isolate the ambient radiation at the low voltage circuit end to prevent the PD measurement circuit from being interfered with by external noise.



Anti-interference structure design

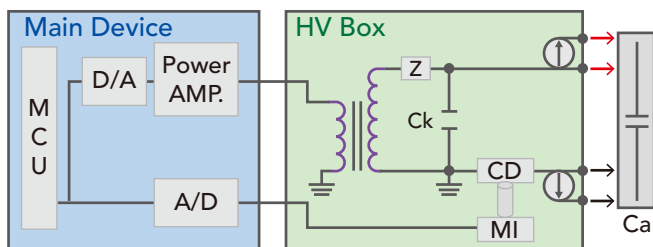

Chroma 19501-K: Uses separate architecture design which helps reduce interference from high frequency radiation ensuring measurement accuracy.

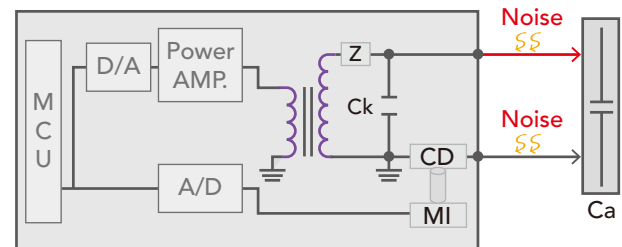

PD testers of other brands: Elongate the test cable to make contact with the DUT, which allows for interference due to the high frequency radiation in the surrounding environment, resulting in inaccurate measurements.

## APPLICATIONS

### Application of optocoupler standards

In the IEC 60747-5-5 standard, the electrical safety requirements and test methods related to optocouplers are clearly defined to provide guidance for safe use of the optocoupler components. The Chroma 19501-K partial discharge tester complies with the electrical safety test requirements and test methods specified in the standard in which partial discharge test must be executed 100% and provided to the manufacturer for optocouplers production. The voltage for the partial discharge test is set by multiplying the nominal maximum insulation working voltage or the maximum repetitive insulation peak voltage (whichever is higher) by 1.875 times to be the partial discharge test voltage. The calculation formula is as follows:

$$V_{pd} = F \times V_{IOWM} \text{ if } V_{IOWM} > V_{IORM}$$

Multiplying factor: F

\* At routine test stage F = 1.875

\* At sample test stage F = 1.6

\* After endurance tests F = 1.2

$V_{IOWM}$  : Maximum working isolation voltage

$V_{IORM}$  : Maximum repetitive peak isolation voltage

### Compliant with IEC 60747-5-5 and VDE 0884 standards for testing

The Chroma 19501-K has built in test methods (b1), (b2) and (b3) required by the IEC60747-5-5 standard for the optocoupler industry, and uses graphical display to assist in program editing, which facilitates the instrument operation and improves the usage efficiency.



Method (b1)



Method (b2)



Method (b3)

### Three stages of voltage test

In addition to meeting the optocoupler and partial discharge testing requirements during production, some manufacturers request a higher test voltage to perform a hipot test with PD detection for improving the quality of the components and maintaining stricter internal quality control. However, the voltage still needs to be reduced to the standard specified (Vpd) for inspection again after the strict test to make sure the product complies with the standard requirement. The Chroma 19501-K unique three stages voltage testing function is designed to satisfy these demands.



### PD failure count setting

The partial discharge tester must be able to accurately measure the tiny discharge when performing insulation quality test on the components. When PD occurs, the signal is very small and easily interfered with by the high frequency radiation in the environment, which causes the measurement to deviate. Therefore, to reduce the misjudgment caused by the external interference, the Chroma 19501-K partial discharge tester provides the settings of PD failure count ensuring the measured discharge capacity is from the DUT instead of the surrounding environment.

When a partial discharge tester applies high voltage to a solid insulator, the discharge capacity in it follows the voltage change to generate periodical discharge. Therefore, the discharge capacity is relatively stable and continuous compared to the high frequency noise in the environment. The 19501-K is designed to calculate the discharge capacity that is generated at least once for four consecutive voltage half-wave periods, and count once when it exceeds the maximum discharge capacity. If the discharge does not occur continuously, the PD failure count will reset to zero and recount until the continuous count exceeds the set number and the test result is determined as a failure.

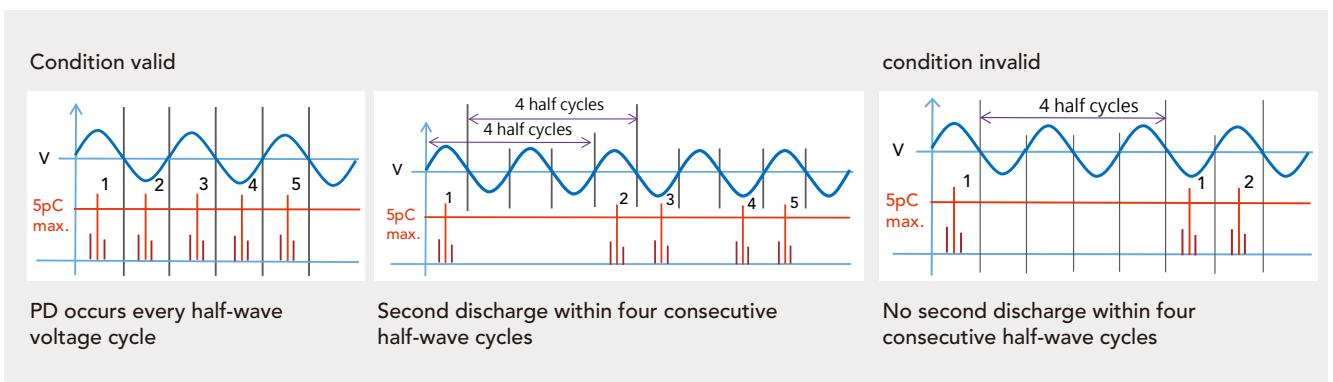

Example Description - The number of PD failures is set to 5 P.D

### HVCC (High Voltage Contact Check)

It is very important to perform contact check on high insulation components during high voltage output. Chroma's unique HVCC (High Voltage Contact Check) function uses Kelvin measurement to perform contact test on the high insulation components when the high voltage outputs, which concurrently increases the test reliability and productivity. The wiring circuit diagram is shown as below.

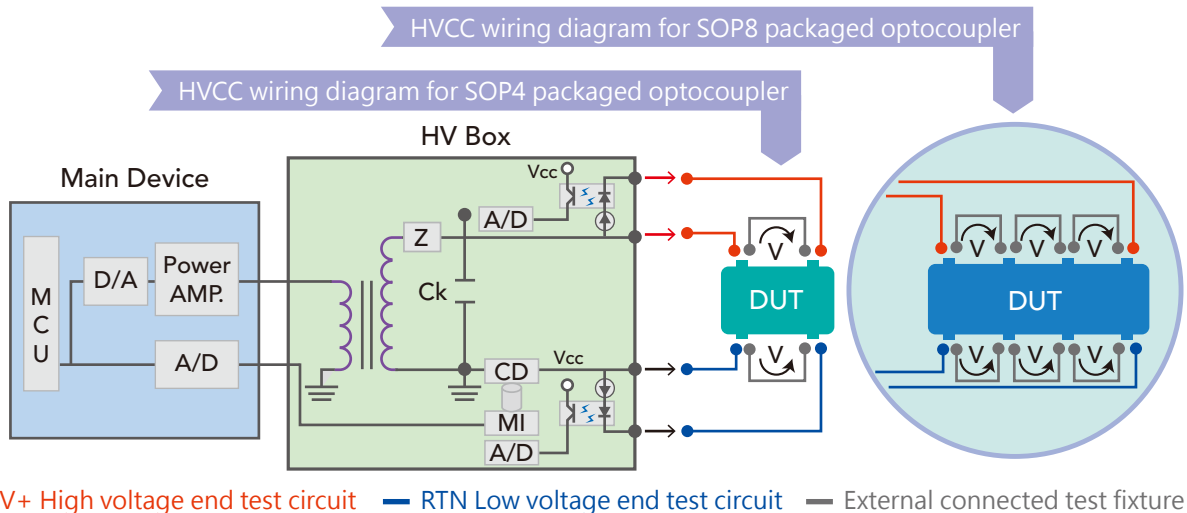

— HV+ High voltage end test circuit — RTN Low voltage end test circuit — External connected test fixture

## SPECIFICATIONS

Model	19501-K
<b>AC Output Voltage</b>	
Range	0.10 kV~10.00 kV, steps 0.01 kV
Voltage Accuracy	±(1% of setting + 0.5% full Scale)
Load Regulation	±(1% of setting + 0.5% full scale)
Frequency	50Hz, 60Hz ± 0.1%, sine wave
<b>Measurement</b>	
V-display Accuracy	± (1% of reading + 0.5% full scale), 10V resolution
Cutoff Current	0.01μA~300.0μA
Leakage Current Meter	30μA : 0.50μA~29.99μA ; 300μA : 30.00~300.0μA Accuracy ± (1% of reading + 2% full scale)
<b>Partial Discharge Detector</b>	
Range	200pC: 1.0 pC~200 pC, 0.1 pC resolution ; 2000pC: 10 pC~2000 pC, 1 pC resolution
Accuracy	± (1% of reading + 0.5% full scale)
Test TimerTest time	0.3~99.9 sec., steps 0.1 sec.
Ramp/Fall time	0.1~9.9 sec., steps 0.1 sec
PD detection delay time:	0~9.9 sec., steps 0.1 sec.
HVCC	* Added HV & RTN contact terminal, test current <10mA and open voltage is 5Vdc typ. * Check function to select ON or OFF
Handler interface	36 pins connector, all input/output are negative true logic and optically isolated open collector signals. (General-speed photo-coupler used) * all outputs must be pulled up with 10kohm resistor to +VEXT (external power supply) * all input optic-diode must be series with current limit (10mA±4mA for +3V ~ +26V) circuit
<b>Remote Interface</b>	
RS-232	The programming language is SCPI
USB (B-type)	Meet USB TMC
LAN	Support 10M/100M Ethernet
Memory Storage	200 instrument setups
USB Flash Drive (A-type)	Test parameters, result and waveform (BMP) storage. (EXP. function) One memory of test procedure and parameter can be storage/recall Backup/restore all memory data to USB flash Support USB Flash up to 32GB in size
<b>General</b>	
Specifications Range	18 to 28 °C (64 to 82°F), 70% RH
Operable Range	0 °C to 45 °C, 15% to 95% RH @ ≤40 °C and no condensation
Storage Range	-10°C to 50 °C, ≤ 80% RH
Power Requirement	100 Vac ~ 240 Vac, 50/60 Hz
Power Consumption	No Load : <150W, Rated Load : <400W
Dimension (WxHxD)	Host: 428x176x500 mm / 16.9x6.9x19.7 inches HV Box: 203x307x200 mm / 8x12.1x7.9 inches
Weight	Host: 20.5 kg / 45.19 lbs HV Box: 13.2 kg / 29.10 lbs
<b>Model A195001</b>	
Output Voltage	1~100V
Polarity	Negative
Range	1,5,100pC in 200pC range ; 20,100,2000pC in 2000pC range
Accuracy	± (3% of reading + 0.5pC)
Rise Time	<50nS
Pulse Repetition	100Hz
Injection Capacitance	1pF
Operable Range	0°C to 45°C, 15% to 95% RH@ ≤40°C and no condensation
Storage Range	-10 to 50°C, ≤ 80% RH
Power Supply	9V battery
Current Consumption	50mA max.
Dimension (WxHxD)	100 x 58 x 151.7 mm / 3.94 x 2.28 x 5.97 inch
Weight	Approx. 1.25kg

\* Specifications are subject to change without notice.

## ORDERING INFORMATION

19501-K : Partial Discharge Tester  
A195001: PD Calibrator



## PANEL DESCRIPTION

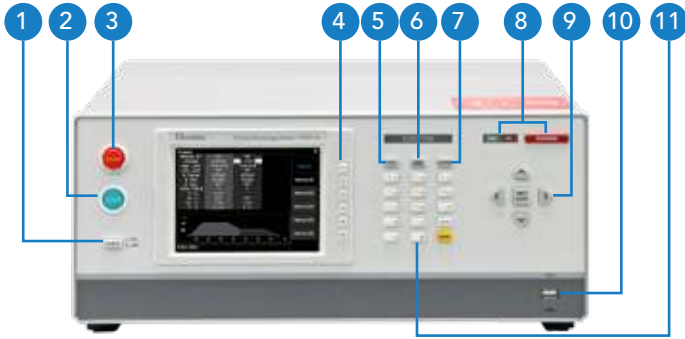

- 1. Power button
- 2. Start testing button
- 3. Stop testing button
- 4. Function key
- 5. Test page button
- 6. Home page button
- 7. System page button
- 8. Test indicator
- 9. Arrow and input key
- 10. USB storage interface
- 11. Numerical editing key

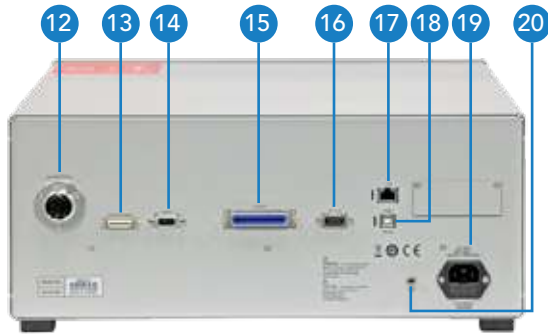

- 12. High voltage module power connector
- 13. Signal control connector
- 14. Option
- 15. HANDLER interface: Connect to the PLC controller
- 16. RS-232 interface: Connect to PC for control
- 17. LAN interface: Connect to PC for control
- 18. USB interface: Connect to PC for control
- 19. Host power connector
- 20. Grounding terminal



- 1. High voltage module power indicator
- 2. Safety switch INTER LOCK
- 3. High voltage module power connector
- 4. Signal control connector
- 5. Grounding terminal

Get more product & distributor information in Chroma ATE APP



iOS





Android

Search Keyword

19501-K

HEADQUARTERS  
CHROMA ATE INC.  
66 Huaya 1st Road,  
Guishan, Taoyuan  
33383, Taiwan  
T +886-3-327-9999  
F +886-3-327-8898  
www.chromaate.com  
info@chromaate.com

U.S.A.  
CHROMA SYSTEMS  
SOLUTIONS, INC.  
19772 Pauling,  
Foothill Ranch,  
CA 92610  
T +1-949-600-6400  
F +1-949-600-6401  
www.chromausa.com  
sales@chromausa.com

EUROPE  
CHROMA ATE  
EUROPE B.V.  
Morsestraat 32,  
6716 AH Ede,  
The Netherlands  
T +31-318-648282  
F +31-318-648288  
www.chroma.eu.com  
sales@chroma.eu.com

CHROMA GERMANY GMBH  
Südtiroler Str. 9, 86165,  
Augsburg, Germany  
T +49-821-790967-0  
F +49-821-790967-600  
www.chroma.eu.com  
sales@chroma.eu.com

JAPAN  
CHROMA JAPAN  
CORP.  
888 Nippa-cho,  
Kouhoku-ku,  
Yokohama-shi,  
Kanagawa,  
223-0057 Japan  
T +81-45-542-1118  
F +81-45-542-1080  
www.chroma.co.jp  
info@chroma.co.jp

KOREA  
CHROMA ATE  
KOREA BRANCH  
3F Richtogether  
Center, 14,  
Pangyojeok-ro 192,  
Bundang-gu,  
Seongnam-si,  
Gyeonggi-do  
13524, Korea  
T +82-31-781-1025  
F +82-31-8017-6614  
www.chromaate.co.kr  
erica.shih@chromaate.co.kr

CHINA  
CHROMA ELECTRONICS  
(SHENZHEN) CO., LTD.  
8F, No.4, Nanyou Tian  
An Industrial Estate,  
Shenzhen, China  
T +86-755-2664-4598  
F +86-755-2641-9620  
www.chroma.com.cn  
info@chromaate.com

SOUTHEAST ASIA  
QUANTEL PTE LTD.  
(A company of Chroma Group)  
46 Lorong 17 Geylang # 05-02  
Enterprise Industrial Building,  
Singapore 388568  
T +65-6745-3200  
F +65-6745-9764  
www.quantel-global.com  
sales@quantel-global.com